

Reactor Error Code Trouble Shooting Guide

Troubleshooting guide



REACTOR™

Rev 2.5
EN

Electric, Heated, Plural Component Proportioner. For spraying polyurethane foam and polyurea coatings. For professional use only.

Not approved for use in European explosive atmosphere locations.



Important Safety Instructions

Read all warnings and instructions in this manual. Save these instructions.

Model E-XP1 Shown

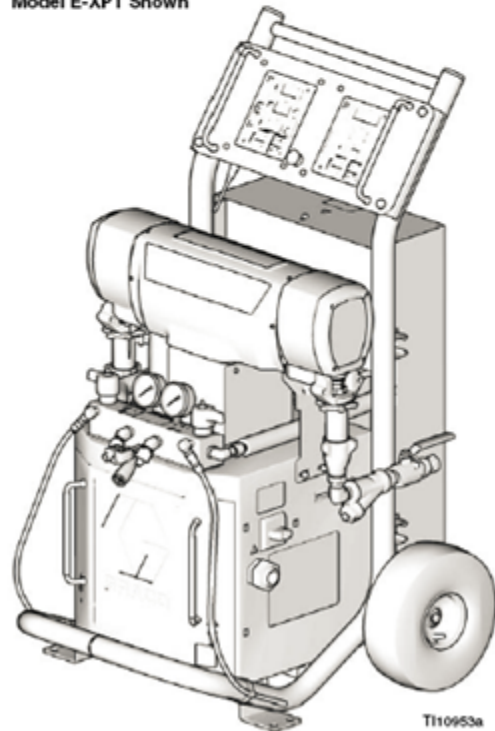

Russian Patent No. 2359181
Taiwan Patent No. 1 303996
Australian Patent No. 2003291660
Other patents pending.

T110953a





Reactor Error Code Trouble Shooting Guide

This is not a substitution for the Operations or Repair instruction manual.









Read, understand and follow all instruction manuals and warning labels supplied with all equipment. Only trained and qualified personnel should perform repairs on the equipment. To access the latest manuals in your preferred language go to “www.graco.com” and use the “Search” function.

Warnings

The following warnings are for the setup, use, grounding, maintenance, and repair of this equipment. The exclamation point symbol alerts you to a general warning and the hazard symbol refers to procedure-specific risk. Refer back to these warnings. Additional, product-specific warnings may be found throughout the body of this manual where applicable.

 WARNING	
	<p>ELECTRIC SHOCK HAZARD Improper grounding, setup, or usage of the system can cause electric shock.</p> <ul style="list-style-type: none"> • Turn off and disconnect power cord before servicing equipment. • Use only grounded electrical outlets. • Use only 3-wire extension cords. • Ensure ground prongs are intact on sprayer and extension cords. • Do not expose to rain. Store indoors.
	<p>TOXIC FLUID OR FUMES HAZARD Toxic fluids or fumes can cause serious injury or death if splashed in the eyes or on skin, inhaled, or swallowed.</p> <ul style="list-style-type: none"> • Read MSDS's to know the specific hazards of the fluids you are using. • Store hazardous fluid in approved containers, and dispose of it according to applicable guidelines. • Always wear impervious gloves when spraying or cleaning equipment.
	<p>PERSONAL PROTECTIVE EQUIPMENT You must wear appropriate protective equipment when operating, servicing, or when in the operating area of the equipment to help protect you from serious injury, including eye injury, inhalation of toxic fumes, burns, and hearing loss. This equipment includes but is not limited to:</p> <ul style="list-style-type: none"> • Protective eyewear • Clothing and respirator as recommended by the fluid and solvent manufacturer • Gloves • Hearing protection
	<p>SKIN INJECTION HAZARD High-pressure fluid from gun, hose leaks, or ruptured components will pierce skin. This may look like just a cut, but it is a serious injury that can result in amputation. Get immediate surgical treatment.</p> <ul style="list-style-type: none"> • Engage trigger lock when not spraying. • Do not point gun at anyone or at any part of the body. • Do not put your hand over the spray tip. • Do not stop or deflect leaks with your hand, body, glove, or rag. • Do not spray without tip guard and trigger guard installed. • Follow Pressure Relief Procedure in this manual, when you stop spraying and before cleaning, checking, or servicing equipment. • Tighten all fluid connections before operating the equipment. • Check hoses and couplings daily. Replace worn or damaged parts immediately.

Reactor Error Code Trouble Shooting Guide

 WARNING	
	<p>FIRE AND EXPLOSION HAZARD Flammable fumes, such as solvent and paint fumes, in work area can ignite or explode. To help prevent fire and explosion:</p> <ul style="list-style-type: none"> • Use and clean equipment only in well ventilated area. • Eliminate all ignition sources; such as pilot lights, cigarettes, portable electric lamps, and plastic drop cloths (potential static arc). • Keep work area free of debris, including solvent, rags and gasoline. • Do not plug or unplug power cords or turn lights on or off when flammable fumes are present. • Ground equipment, personnel, object being sprayed, and conductive objects in work area. See Grounding instructions. • Use only Graco grounded hoses. • Check gun resistance daily. • If there is static sparking or you feel a shock, stop operation immediately. Do not use equipment until you identify and correct the problem. • Do not flush with gun electrostatics on. Do not turn on electrostatics until all solvent is removed from system. • Keep a working fire extinguisher in the work area.
	<p>THERMAL EXPANSION HAZARD Fluids subjected to heat in confined spaces, including hoses, can create a rapid rise in pressure due to the thermal expansion. Over-pressurization can result in equipment rupture and serious injury.</p> <ul style="list-style-type: none"> • Open a valve to relieve the fluid expansion during heating. • Replace hoses proactively at regular intervals based on your operating conditions.
	<p>PRESSURIZED ALUMINUM PARTS HAZARD Do not use 1,1,1-trichloroethane, methylene chloride, other halogenated hydrocarbon solvents or fluids containing such solvents in pressurized aluminum equipment. Such use can cause serious chemical reaction and equipment rupture, and result in death, serious injury, and property damage.</p>
	<p>EQUIPMENT MISUSE HAZARD Misuse can cause death or serious injury.</p> <ul style="list-style-type: none"> • This equipment is for professional use only. • Do not leave the work are while the equipment is energized or under pressure. Turn off all equipment and follow the Pressure Relief Procedure in this manual when the equipment is not in use. • Do not operate the unit when fatigued or under the influence of drugs or alcohol. • Do not exceed the maximum working pressure or temperature rating of the lowest rated system component. See Technical Data in all equipment manuals. • Use fluids and solvents that are compatible with equipment wetted parts. See Technical Data in all equipment manuals. Read fluid and solvent manufacturer's warnings. For complete information about your material, request MSDS forms from distributor or retailer. • Check equipment daily. Repair or replace worn or damaged parts immediately with genuine manufacturer's replacement parts only. • Do not alter or modify equipment. • Use equipment only for its intended purpose. Call your distributor for information. • Route hoses and cables away from traffic areas, sharp edges, moving parts, and hot surfaces. • Do not kink or over bend hoses or use hoses to pull equipment. • Keep children and animals away from work area. • Comply with all applicable safety regulations.
	<p>MOVING PARTS HAZARD Moving parts can pinch or amputate fingers and other body parts.</p> <ul style="list-style-type: none"> • Keep clear of moving parts. • Do not operate equipment with protective guards or covers removed. • Pressurized equipment can start without warning. Before checking, moving, or servicing equipment, follow the Pressure Relief Procedure in this manual. Disconnect power or air supply.
 WARNING	
	<p>BURN HAZARD Equipment surfaces and fluid that's heated can become very hot during operation. To avoid severe burns, do not touch hot fluid or equipment. Wait until equipment/fluid has cooled completely.</p>

Reactor Error Code Trouble Shooting Guide

Contents

HEAT CONTROL ERROR LIST

[E01 - High Fluid temperature](#)

[E02 - High Current](#)

[E03 - No current](#)

[E04 - Missing t/c thermocouple](#)

[E05 - Power module over temperature](#)

[E06 - Control module to power module communications error](#)

[E09 - Missing display](#)

[E99 - Display communications error](#)

MOTOR CONTROL ERROR LIST - E and H Series

[E21 - Transducer A faulty](#)

[E22 - Transducer B faulty](#)

[E23 - High Pressure](#)

[E24 - Pressure imbalance](#)

[E25. - High line voltage](#)

[E26 - Low line voltage](#)

[E27 - High motor temp](#)

[E28 - High current, locked rotor](#)

[E29. - Brush wear](#)

[E30 - Display communications error](#)

[E31 - Motor drive fault](#)

[E99 - Display communications error](#)

[Recommended Tech Tools](#)

Reactor Error Code Trouble Shooting Guide

E01: High Fluid temperature [\(Return to Table Of Contents\)](#)

Note: The display that is showing the E01 error is the zone that is seeing the error.

- ✓ **Check to see if you really do have high a temperature, by using an external temperature-sensing device.** If actual fluid temperature is above 190° F (88°C) you will need to cool the unit down to be able to do any testing. Using your feed pumps to move cool material into the Reactor will speed cooling time.

Causes:

- 1) The "A" or "B" Thermocouple (Ref # 310) picked up a high fluid temp of 229°F (109°C) or greater.

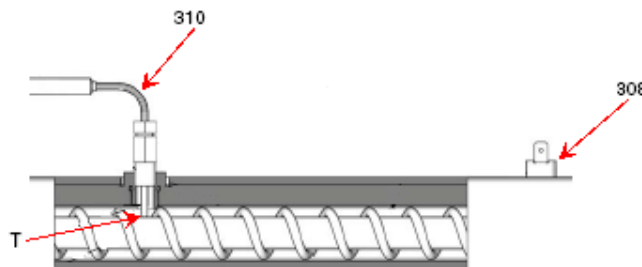

- ✓ Check connections between the temperature control module and the heater "A" & "B" Thermocouples. Make sure all of the wires are securely connected into connector J1/SENSOR B.
- ✓ Check continuity of the "A" & "B" thermocouples by removing the J1/SENSOR B connector from the temperature control module socket. On the plug end check the resistance across pins 5 & 6 = 4 - 6 ohms. Pins 8 & 9 = 4 - 6 ohms. Pins 6 & 9 to chassis ground as "OL" open loop at ambient temperature.

See figure below

Reactor Error Code Trouble Shooting Guide

Temperature Control Module

Table 5: Temperature Control Module Connections

Connector		Description
SENSOR (B) J1	PIN	
	12	HOSE T/C P; FTS (purple)
	11	HOSE T/C R; FTS (red)
	10	HOSE T/C S; FTS (silver (unshielded bare wire))
	9	HEATER T/C B, Y; Thermocouple (yellow)
	8	HEATER T/C B, R; Thermocouple (red)
	7	Not used
	6	HEATER T/C A, Y; Thermocouple (yellow)
	5	HEATER T/C A, R; Thermocouple (red)
	4, 3	OVERTEMPERATURE B; Overtemperature switch B
2, 1	OVERTEMPERATURE A; Overtemperature switch A	

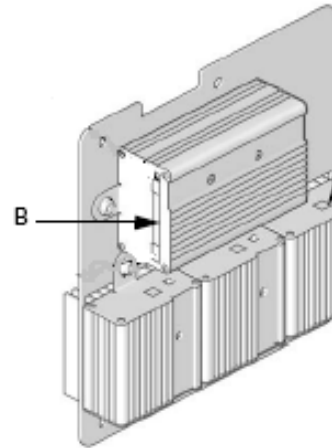

2) One of the over temperature switches (Ref # 308) picked up a high fluid temp greater than 230° F (110°C). At 190° F (88°C) the contacts close again.

- ✓ Check continuity of the over temperature switches by removing the J1/SENSOR B connector from the temperature control module socket. On the plug end check the resistance across pins 1 & 2 and pins 3 & 4 for continuity, (nearly zero ohms).

See figure above

3) Either the "A" or the "B" Thermocouple has failed, or is not in contact with a working heater element.

- ✓ Check and see if the "A" or the "B" Thermocouple is damaged or not making contact with a working heater element. See section Thermocouple in manual 312066 E-Series, 312063 H-Series, 313540 H-VR-Series.

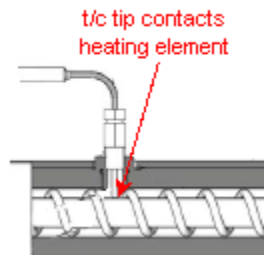

Reactor Error Code Troubleshooting Guide

Primary Heaters / Heater Elements

6.0 kW – 1500w (30-35 ohms) x 2 each per side = 15–17.5 ohms combined.

10.2 kW – 2550w (18-21 ohms) x 2 each per side = 9-10.5 ohms combined.

8.0 kW – 2000w (23-26 ohms) x 2 each per side = 11.5-13 ohms combined.

7.65 kW – 2550w (18-21 ohms) x 3 each per side = 6-7 ohms combined.

10.2 kW and 6.0 kW Fluid Heaters

Parts 247506 and 247507

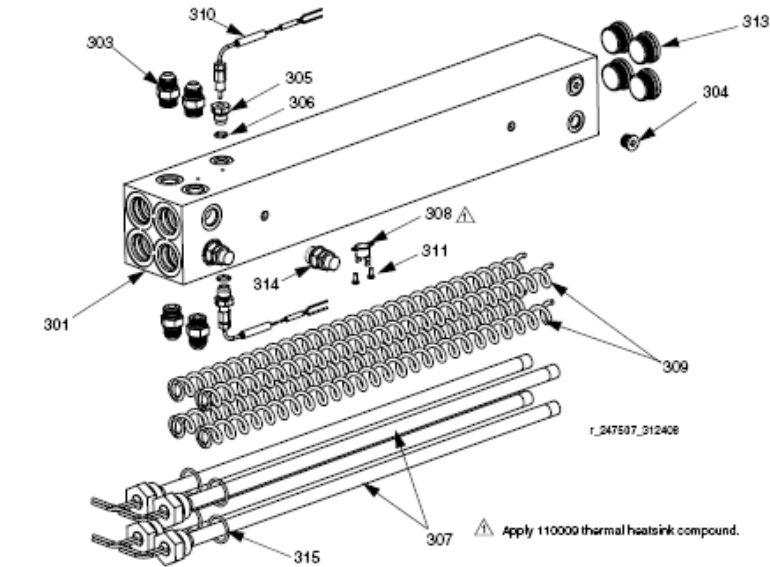

307 HEATER, immersion
16A110 2550W; 10.4 kW heater only
16A112 1500 W; 6.0 kW heater only

4

Reactor Error Code Trouble Shooting Guide

8.0 kW Dual Zone Heater

(One Per Machine)

Part 247815

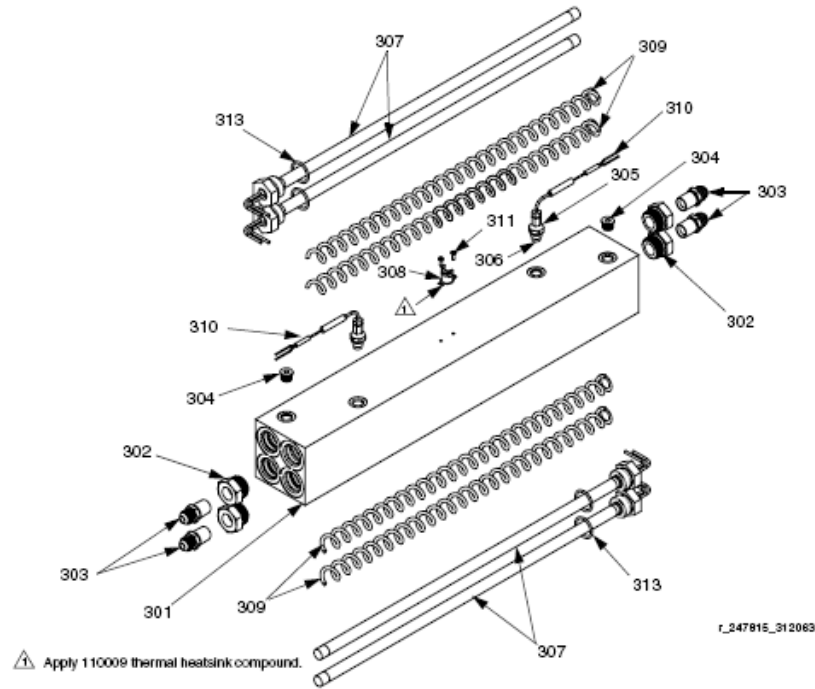

307 16A111 HEATER, immersion; 2000 W 4

Reactor Error Code Troubleshooting Guide

7.65 kW Single Zone Fluid Heater (Two Per Machine)

Part 247509

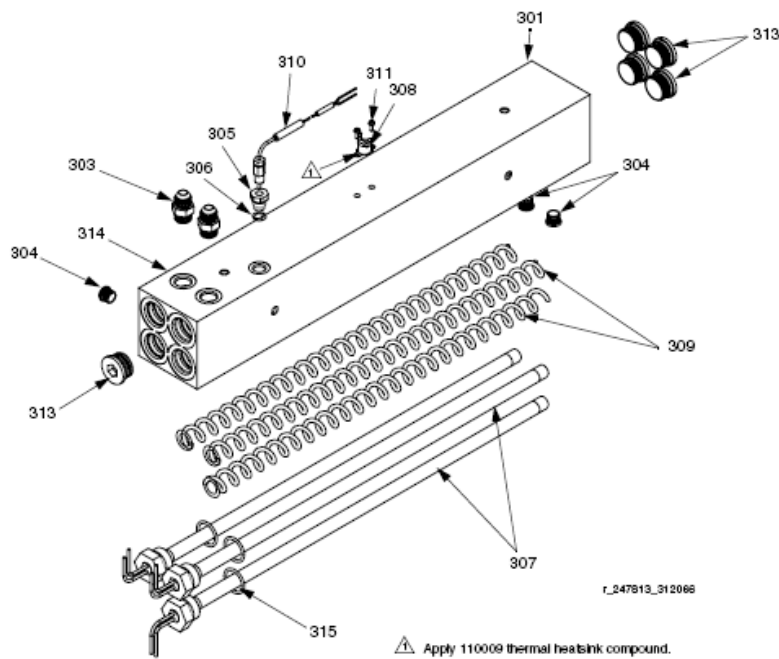

307 16A110 HEATER, immersion; 2550 W 3

4) Heater modules failed to turn off any heat zone, causing a run-away condition.

- ✓ Exchange zone module with another one. Turn zone on and check for error. If error moves to another zone, replace the faulty module. (When there is a high current error, the LED on that zone's module will turn red while the error is displayed.)
- ✓ Check and see if the heater module (BLUE) is turning off when the unit hits the set point temperature.
 - For "A" heater test points T4 on 238CR & T2 on POD A connector.
 - For "B" heater test points T6 on 238CR & T2 on POD B connector.
 - For HOSE test points T1 on 183 CB HOSE & T1 on POD HOSE connector.

Reactor Error Code Trouble Shooting Guide

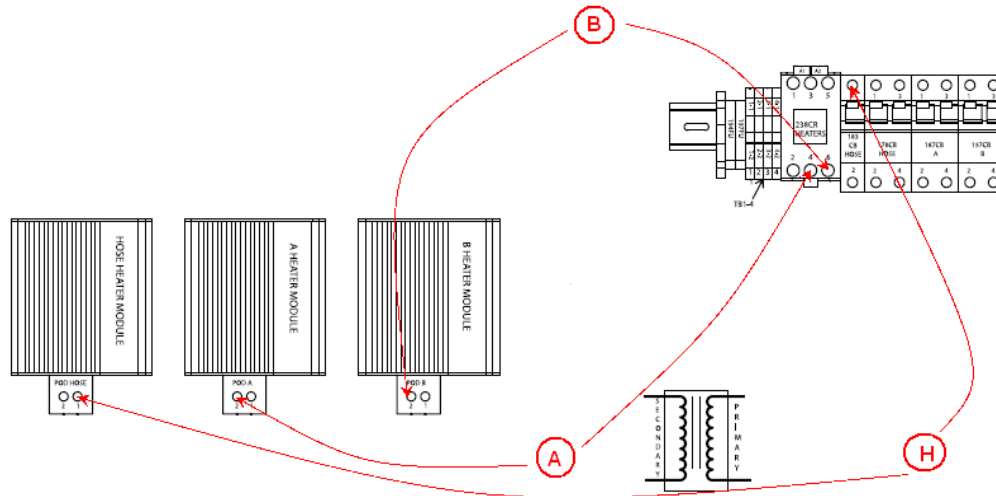

- Set the “A”, “B”, and HOSE set point 10°F/C below the actual temperature, and turn the heat zones on one at a time. The red light on the display above the zone should be blinking and there should be little to no voltage on the voltmeter.
 - Measuring voltage while the red light is blinking would indicate that the output on the heater module has failed. Replace the heater module. *Note: all 3 modules are the same and can be swapped for troubleshooting.*

5) If fluid is below 190° F (88°C) and you are still getting the high temp error:

Causes:

- Faulty connection of either of the "A" & "B" thermocouple to the heater control module
- One of the over temperature switches failed in the “open” position. Open circuit in the over temperature wiring harness, or switch “B” jumper is loose or open on a dual zone heater systems.



Reactor Error Code Trouble Shooting Guide

- ✓ Make sure connector J1/SENSOR B is firmly plugged into the heater control module.
- ✓ Check connections between the temperature control module and the heater over temperature switches and the "A" & "B" temperature sensor. Make sure all of the wires are securely connected into connector J1/SENSOR B.
- ✓ Check continuity of the over temperature switches and the "A" & "B" Thermocouples by removing the J1/SENSOR B connector from the temperature control module socket. On the plug end check the resistance across pins 1 & 2 = nearly Zero ohms, pins 3 & 4 = nearly Zero ohms. Pins 5 & 6 = 4 - 6 ohms. Pins 8 & 9 = 4 - 6 ohms. Pins 6 & 9 to chassis ground as "OL" open loop at ambient temperature.

Temperature Control Module

Table 5: Temperature Control Module Connections

Connector	Description	
SENSOR (B) J1	PIN	
	12	HOSE T/C P; FTS (purple)
	11	HOSE T/C R; FTS (red)
	10	HOSE T/C S; FTS (silver (unshielded bare wire))
	9	HEATER T/C B, Y; Thermocouple (yellow)
	8	HEATER T/C B, R; Thermocouple (red)
	7	Not used
	6	HEATER T/C A, Y; Thermocouple (yellow)
	5	HEATER T/C A, R; Thermocouple (red)
	4, 3	OVERTEMPERATURE B; Overtemperature switch B
	2, 1	OVERTEMPERATURE A; Overtemperature switch A

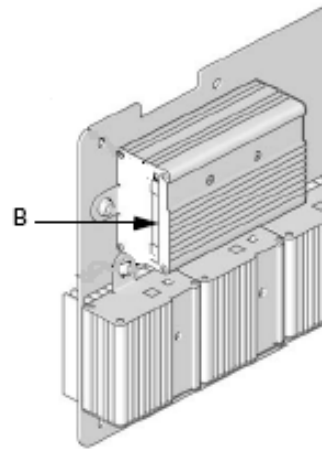

Reactor Error Code Trouble Shooting Guide

E02: High Current [\(Return to Table Of Contents\)](#)

Note: The display that is showing the E02 error is the zone that is seeing the error.

Causes:

1) Electrical short in the heater module.

- Hold down actual temperature key for each zone to view current output when the heat module is on.

- Exchange zone module with another one. Turn zone on and check for error. If error moves to another zone, replace the faulty module. (When there is a high current error, the LED on that zone's module will turn red while the error is displayed.

2) For Hose zone, electrical short in the hose heat transformer

- Check continuity of transformer windings, and if shorted to ground.

- Perform the hose heat transformer primary and secondary check. (see hose heat transformer not functioning section in E03)

Reactor Error Code Trouble Shooting Guide

E03: No Zone Current [\(Return to Table Of Contents\)](#)

Note: The display that is showing the E03 error is the zone that is seeing the error.

Causes:

1) Tripped circuit breaker in the electrical cabinet.

- For HOSE, check 183CB HOSE, and 178 CB HOSE.
- For “A”, 187CB A.
- For “B”, 197CB B.

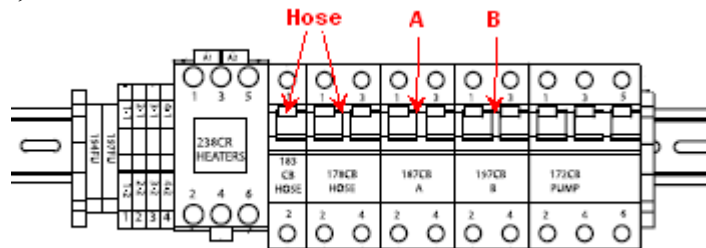

2) Loose or broken connection on that zones output

- Visually inspect and check continuity of wiring harnesses from circuit breaker module, through 238CR contactor, heater modules, and heater.
- Check continuity in the hose set < 3 ohms, out and back, with whip hose attached.

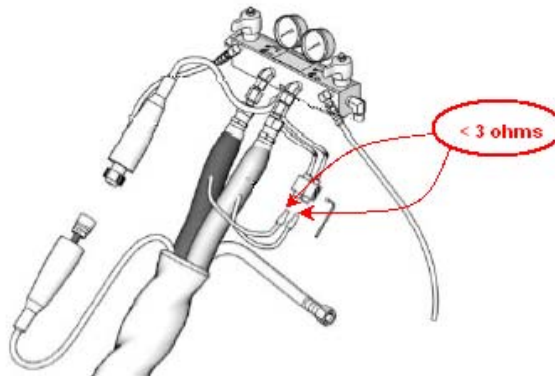

Reactor Error Code Troubleshooting Guide

3) Hose heat transformer not functioning.

Set Hose Zone target key below current actual temperature and turn on the Hose Zone only. (not “A” or “B”)

- Perform transformer secondary check.
 - ✓ Measure 90 – 100 VAC between T1 on 183CB-HOSE and T2 on POD HOSE of Hose Heater Module.
 - If not present measure transformer primary
- Perform transformer primary check.
 - ✓ Measure line voltage between T2 on 238CR and T2 on 178CB-HOSE.

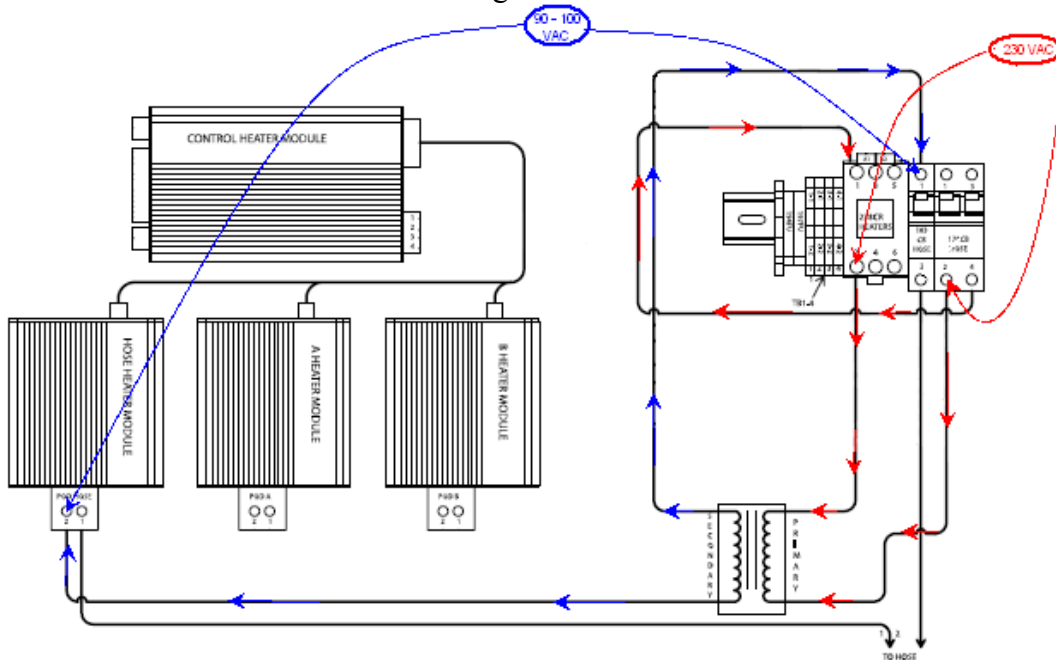

4) Contactor 238CR failed to close contacts.

- Verify line voltage to A1 & A2 of contactor and that all 3 legs pass the proper voltage through to heater modules.

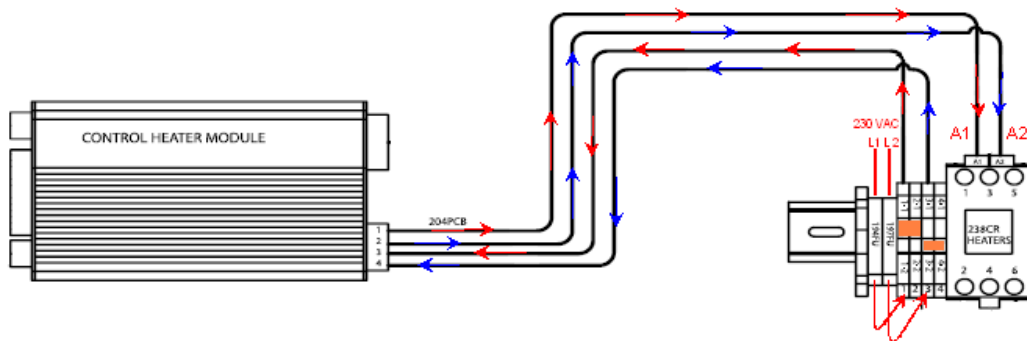

238CR

Reactor Error Code Trouble Shooting Guide

5) Single phasing in a three phase system

- Verify line voltage between all 3 legs of power. L1 to L2, L2 to L3, and L1 to L3.

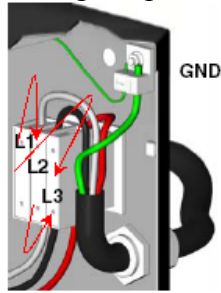

Reactor Error Code Trouble Shooting Guide

E04: Fluid Temperature Sensor (FTS), or “A” or “B”

Thermocouple not Connected. [\(Return to Table Of Contents\)](#)

Note: The display that is showing the E04 error is the zone that is seeing the error.

Causes:

1) E04 on the “A” or “B” display = While the unit was powered on, the thermocouple lost communication with the temperature control module.

➤ Checking the “A” and “B” side thermocouple assemblies.

✓ Check the electrical connections at the temperature control module.

○ Remove plug J1/SENSOR B (Green 12-pin terminal block) from the temperature control module and make sure all pins are securely connected.

- ✓ Pin 5 Thermocouple A - red wire connected.
- ✓ Pin 6 Thermocouple A - yellow wire connected.
- ✓ Pin 8 Thermocouple B - red wire connected.
- ✓ Pin 9 Thermocouple B - yellow wire connected.

○ Check the “A” & “B” thermocouples by removing the J1/SENSOR B connector from the temperature control module and check the pins with an ohmmeter.

“A” thermocouple:

- ✓ With J1/SENSOR B disconnected measure the resistance across pins 5 & 6. It should measure 4 - 6 Ohms at ambient temperature. If not, replace the “A” thermocouple.
- ✓ Measure the resistance between Pin 5 & the thermocouple housing. And then between Pin 6 & the thermocouple housing. It should be “OL” open loop, if not replace the “A” thermocouple.

“B” thermocouple:

- ✓ With J1/SENSOR B disconnected measure the resistance across pins 8 & 9. It should measure 4 - 6 Ohms at ambient temperature. If not, replace the “B” thermocouple.
- ✓ Measure the resistance between Pin 8 & the thermocouple housing. And then between Pin 9 & the thermocouple housing. It should be “OL” open loop, if not replace the “B” thermocouple.

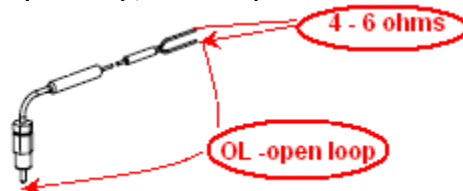

Reactor Error Code Troubleshooting Guide

2) E04 on the hose heat display = While the unit was powered on, the Fluid Temperature Sensor (FTS) lost communication with the temperature control module.

- ✓ Check the electrical connections at the temperature control module.
 - Looking at plug J1/ SENSOR B on the temperature control module, check and see if pins 10, 11 & 12 are connected properly.
 - Pin 12 = purple
 - Pin 11 = red
 - Pin 10 = silver (unshielded bare wires)
- ✓ Check the purple wire cable connections between all hose lengths with FTS attached...
 - Test with an Ohm meter between pins 10 (Silver unshielded bare wire), 11 Red wire, and 12 (Purple wire) of J1/SENSOR B connector disconnected from the Temperature Control Module.
 - Pins 11 to 12 approximately 35 ohms per 50' (15.2m) of FTS cable, plus 10 ohms for the FTS.
 - Pins 10 to 12 “OL” open loop > 100K ohms.

3. Disconnect FTS cable (F) at Reactor, Fig. 8.

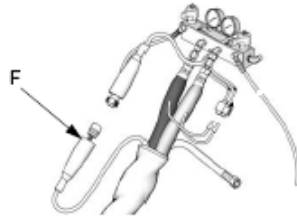

Fig. 8. Heated Hose

4. Test with ohmmeter between pins of cable connector.

Pins	Result
1 to 2	approximately 35 ohms per 50 ft (15.2 m) of hose, plus approximately 10 ohms for FTS
1 to 3	infinity

- ✓ Check the FTS operation by connecting the FTS directly to the Reactor.
 - Locate the FTS.
 - ✓ Unplug the FTS electrical connection.
 - ✓ Plug the Reactor end of the connector directly into the FTS electrical connector to see if temperature data appears.

Reactor Error Code Trouble Shooting Guide

- ✓ Check the FTS with an ohmmeter.
 - Locate the FTS.
 - With the main power off, unplug the FTS and measure the pins on the FTS.
 - ✓ Pins 1 to 2 \cong 10 Ohms
 - ✓ Pins 1 to 3 = Infinity “OL” Open Loop
 - ✓ Pin 3 to FTS ground screw = 0 ohms
 - ✓ Pin 1 to FTS component “A” (ISO) fitting = Infinity
- If the FTS fails any test, replace.

0A (zero amps) on the Hose Zone Display.

- If the FTS is disconnected or the display shows E04, turn the main disconnect off, then on to clear the alarm, and default the machine into manual current hose heat mode. 0A (zero amps) will show in the actual display with the hose zone off.
- When in the target mode of the hose heat zone, amperage can be adjusted from 20A to 45A with the up and down arrow keys.
- To prevent hose overheating, install a thermometer close to the gun end, within the operators view. Insert thermometer through foam insulation cover of the “A” component hose so stem is next to the inner tube. Thermometer reading will be approximately 20°F less than the actual fluid temperature. If the thermometer reading exceeds 160°F (71°C), reduce the current with the down arrow key.
- ***Thermometer reading should never exceed 160°F (71°C). Never leave the machine unattended while in a manual current control mode.***

Reactor Error Code Trouble Shooting Guide

E05: Control Module Over Temperature [\(Return to Table Of Contents\)](#)

Cause:

- The control module has an on-board temperature sensor. Heat is turned off if the module temperature exceeds 185°F (85°C) to prevent damage to the circuit board. (See also High Motor Temp section under E27).

E06: Communication Cable Unplugged [\(Return to Table Of Contents\)](#)

Causes:

- 1) **Communication cable that connects heater control module (Silver) to the heater modules (Blue) connection is loose or dirty.**

Unplug and re-plug cable that connects heater control module (Silver) to the heater modules (Blue).

- 2) **Communication cable faulty.**

Check the cable connections end to end for continuity. If problems persist, replace the cable. p/n- 247801

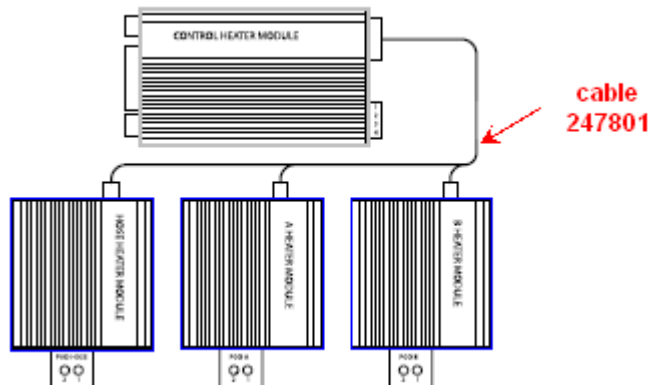

Reactor Error Code Trouble Shooting Guide

E09: Heater and Display Communication Malfunction

[\(Return to Table Of Contents\)](#)

Cause:

1) **Communications between the heater control module and the display is not functioning.**

When communication is lost, the display will show E09.

- ✓ **Check all wiring between the display and the heater control module.**
 - Pay close attention to the wire crimping on plug J5/DISPLAY C of temperature control module.
 - Swap J5 of temp control side with J13 on motor control side to see if problem is in the harness/control or display.
 - If E09 remains on the same display, replace the Display
 - If E09 moves to other display then reverse the J13 connections on the display boards to determine if cable or temperature control module is the cause.

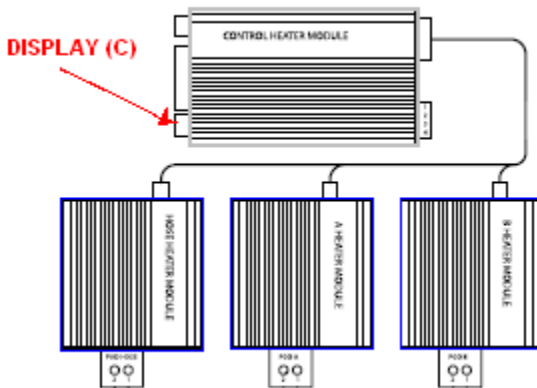

Reactor Error Code Trouble Shooting Guide

E21: No Component A Transducer [\(Return to Table Of Contents\)](#)

Causes:

- 1) Faulty pressure transducer 24K999.

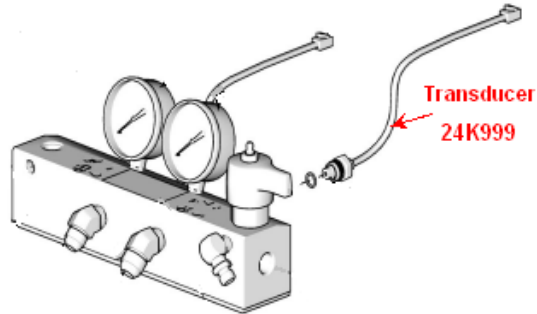

- 2) Faulty connection on J3/J5 of motor control board.

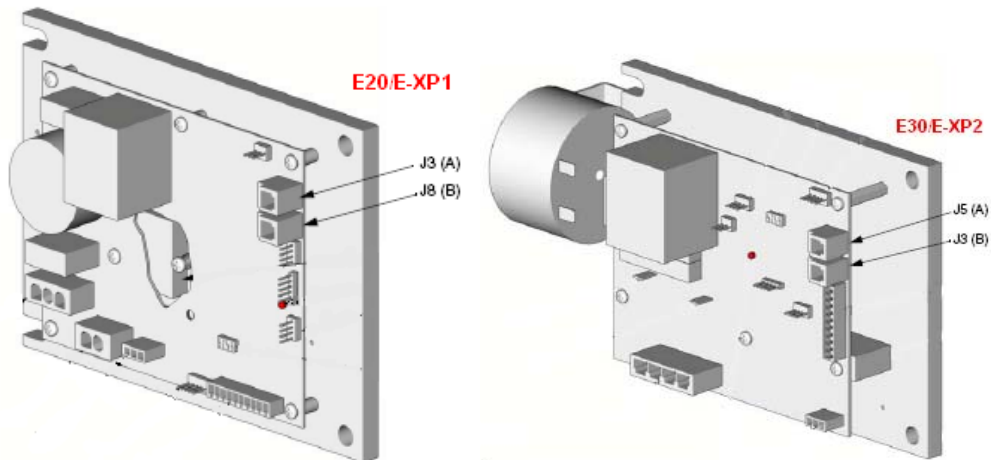

All H-series Reactors

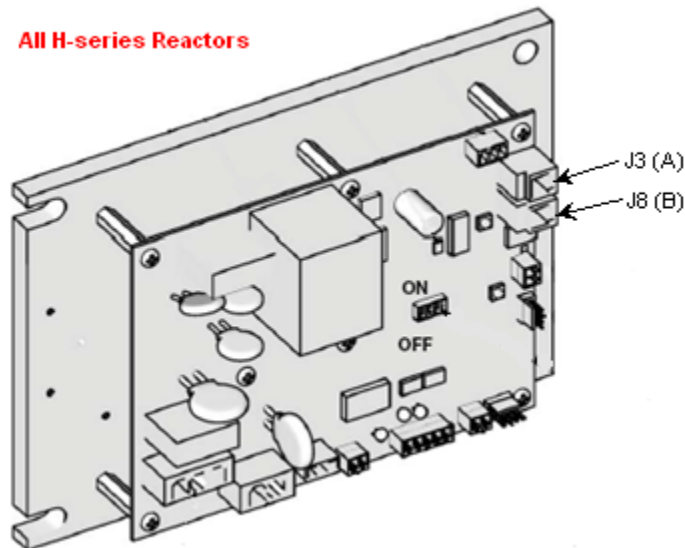

Reactor Error Code Trouble Shooting Guide

3) Checking for a E21 error

- Check transducer A connection at J3, (E-20/E-XP1, H-series) or J5, (E-30/E-XP2) on motor control board.
- Clean the plug and socket of transducer connection by unplugging and spraying commercially available contact cleaner and reconnecting.
- Reverse A and B transducer connections. If error moves to transducer B (E22), replace the transducer A. If error does not move then replace the motor control board.

Reactor Error Code Trouble Shooting Guide

E22: No Component B Transducer [\(Return to Table Of Contents\)](#)

Causes:

- 1) **Faulty pressure transducer 24K999.**
- 2) **Faulty connection on J8/J3 of motor control board.**
- 3) **Checking for a E22 error**
 - Check transducer B connection at J8, (E-20/E-XP1, H-series) or J3, (E-30/E-XP2), on motor control board.
 - Clean the plug and socket of transducer connection by unplugging and spraying commercially available contact cleaner and reconnecting.
 - Reverse B and A transducer connections. If error moves to transducer A (E21), replace the transducer B. If error does not move then replace the motor control board.

Reactor Error Code Trouble Shooting Guide

E23: High Pressure [\(Return to Table Of Contents\)](#)

Causes:

1) Jumper wire on plug J10 (E-20/E-XP1) or J7 (E-30/E-XP2) pin 7 to pin 10 on the motor control board is loose or has become disconnected.

- On the current units without the over pressure switches Check the jumpers and the wiring.

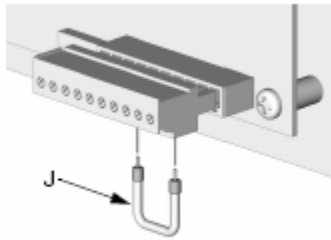

E20/E-XP1 Motor Control Board

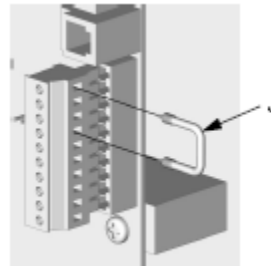

E30/E-XP2 Motor Control Board

- **On the older units with the Pressure switches.**

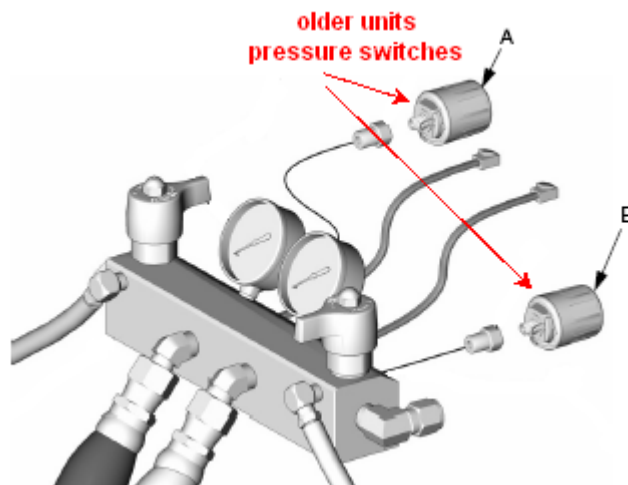

- ✓ Check to see if one of the pressure switches failed.
 - 1) Remove the plug J10 (E20/E-XP1) or plug J7 (E30/E-XP2).
 - 2) Measure the resistance between pins 7 and 8, and between 9 and 10. Measurement should be $\cong 1$ ohm.
- If the resistance in steps 2 & 3 is not $\cong 1$ ohm, jumper pins 7 to 10. order repair kit 246961.
- If the error persists after connecting pin 7 to pin 10 with jumper, replace the motor control board, along with kit 246961

Reactor Error Code Trouble Shooting Guide

2) The Reactor motor control board is receiving a signal from the “A” or “B” pressure transducer that is above 3000 psi for (E-20, E-30, H-25, H-40, H-50), or above 4500 psi for (E-XP1, E-XP2, H-XP2, H-XP3).

- Clean the plug and socket of transducer connection by unplugging and spraying commercially available contact cleaner and reconnecting.
 - If the wire jumper and the wiring are in good working condition and you still have the error, then you will need to check the “A” & “B” pressure transducers. (See transducer check procedure under E24 section.)
 - To determine if it’s the “A” or the “B” transducer, you may need a known good Reactor pressure transducer 24K999 to use as a “test” transducer. The test is going to be done without removing the existing pressure transducers from the fluid manifold.
- ✓ Unplug the “A” transducer from the Motor control board socket J3, (E-20/E-XP1) or J5, (E-30/E-XP2) **and** plug in the “Test” pressure transducer in its place.
 - ✓ Turn on the Reactor main disconnect and see if the error has went away.
 - ✓ If the error goes away turn off the Reactor main power and remove & replace the “A” pressure transducer.
 - ✓ If the error didn’t go away, unplug the “test” transducer from the “A” socket, and reinstall the “A” pressure transducer back into the “A” socket, and repeat this test procedure on the “B” side J8, (E-20/E-XP1) or J3, (E-30/E-XP2).
- ! If the error persists and no root cause is found through the above testing, replace the motor control board.

3) Motor control board is shorted (E-series).

- Not in all cases will an E31 error code appear. Another symptom of a motor drive failure is that the motor will immediately turn on when input power is applied to the Reactor, running away with no motor control. This is due to the control being shorted sending full vdc to the motor. If the motor runs as soon as power is applied to the machine, replace the motor control board after verifying input voltage

Reactor Error Code Trouble Shooting Guide

4) Material cavitation A or B side.

- Verify feed supply pumps or ball valves are not off.
- That the material drums are not empty.
- That the filter strainers are not restricted.
- That the Reactor pumps are working properly.
(See “If the gauges are not reading equal” section under E24)

5) Material heater stays ON, causing excessive pressure due to thermal expansion.

(See “Heater modules failed to turn off any heat zone, causing a run-a-way condition” section under E01.

6) On older E-series units, the over pressure switches (Ref. 703) has failed.

Jumper terminal 7 to 10 with kit 246961

Reactor Error Code Troubleshooting Guide

E24: Pressure Imbalance ([Return to Table Of Contents](#))

There is a pressure imbalance between the “A” and “B” fluids that is higher than allowed by the motor control board. Available control settings are between 100 – 999 psi, or 7 – 35 bar. See table 3 below.

To change the pressure imbalance setting:





- Turn main power switch OFF 
- Press and hold **PSI** or **BAR**, then turn main power switch ON . Display will read dP500 for psi or dP_35 for bar.
- Press  or  to select desired pressure differential (100-999 in increments of 100 psi, or 7-35 in increments of 7 bar). See Table 3.

Table 3: Available Pressure Imbalance Settings

PSI	BAR	PSI	BAR
100	7	600	42
200	14	700	49
300	21	800	56
400	28	900	63
*500	*35	999	69

* Factor default setting.

- Turn main power switch OFF  to save changes.

Causes:

There can be two types of E24 errors, depending on whether the pressure gauges are approximately equal, or not equal.

1) If analog gauges are reading equal.

Causes:

- One of the pressure transducers has failed, or
- Pressure imbalance setting is too low for application.

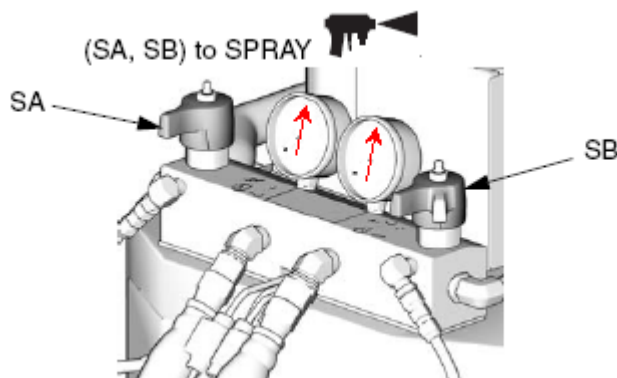

Reactor Error Code Troubleshooting Guide

1a) One of the pressure transducers has failed.

- The digital display on a Reactor always shows the higher of the two pressures. As soon as the higher analog pressure drops below the lower analog pressure the digital display will switch to the new highest reading. Knowing this, the following tests should show which pressure transducer has failed.
- For testing purposes only – Find the dip switches (labeled SW2 in the manual) on the motor control board, and set dipswitch 3 to off on E-Series Reactors, dipswitch 2 off for H-Series Reactors. This will allow the Reactor to run with a pressure imbalance warning.

24G879 Motor Control, for E-20 and E-XP1

DIP Switch (SW2) Settings

Model E-20



Model E-XP1



Place sw 3 in the down position for test

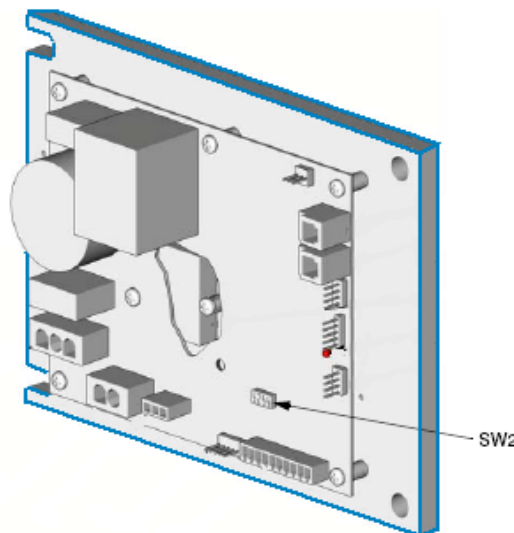

24G881 Motor Control, for E-30 and E-XP2

DIP Switch (SW2) Settings

Model E-30



Model E-XP2



Place sw 3 in the up position for test

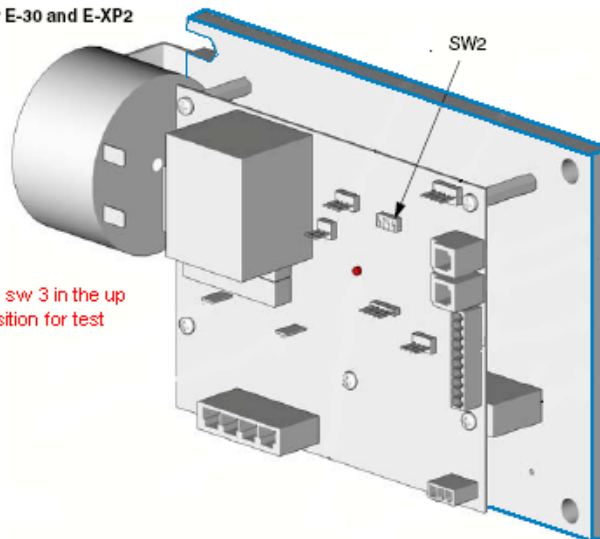

Reactor Error Code Trouble Shooting Guide

Motor Control

DIP Switch (SW2) Settings

Models H-25, H-40, H-50

ON



Models H-XP2 & H-XP3

ON

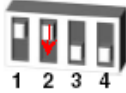

Place sw 2 in the down position for test

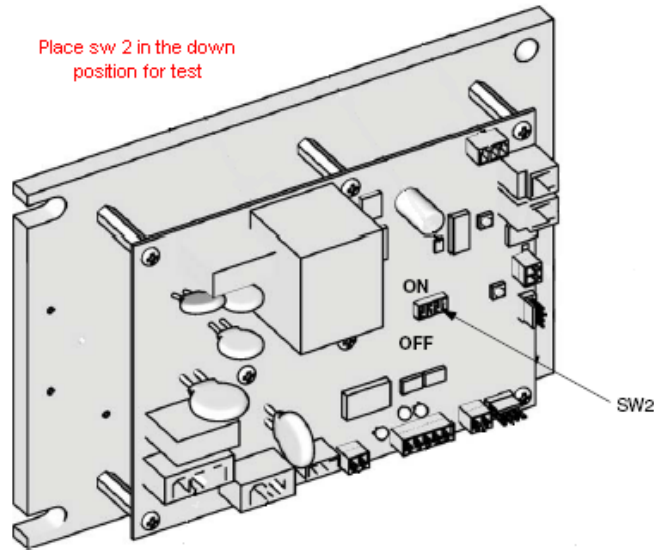

- Run the unit to build up pressure (1000 – 1200 psi) with the motor ON key. When the machine then stalls at set pressure, press the motor OFF key to clear the E24 warning, but don't depressurize the unit.

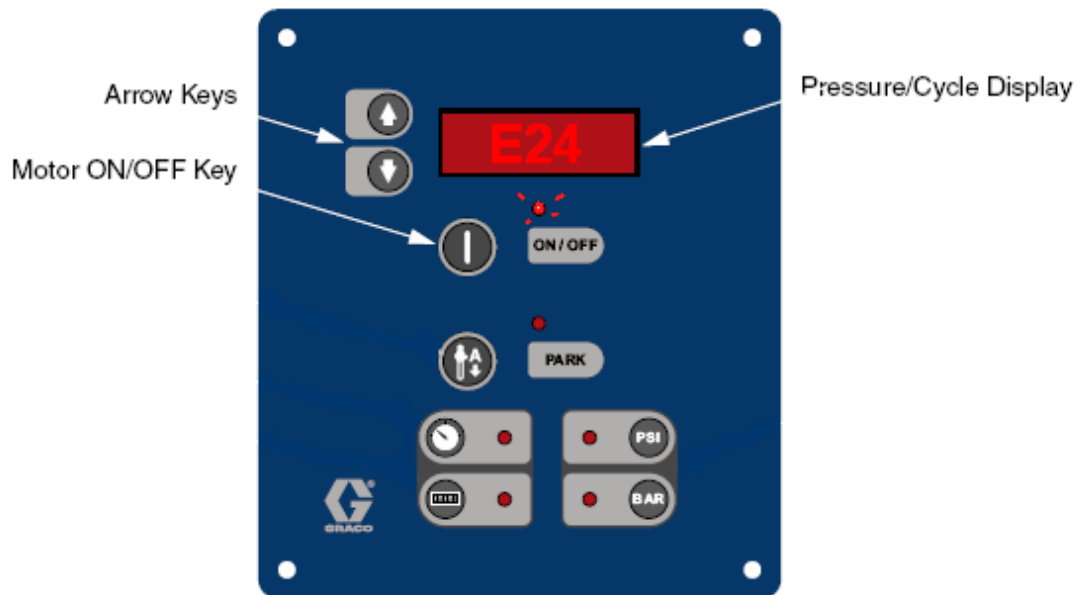

Motor Controls and Indicators

Reactor Error Code Troubleshooting Guide

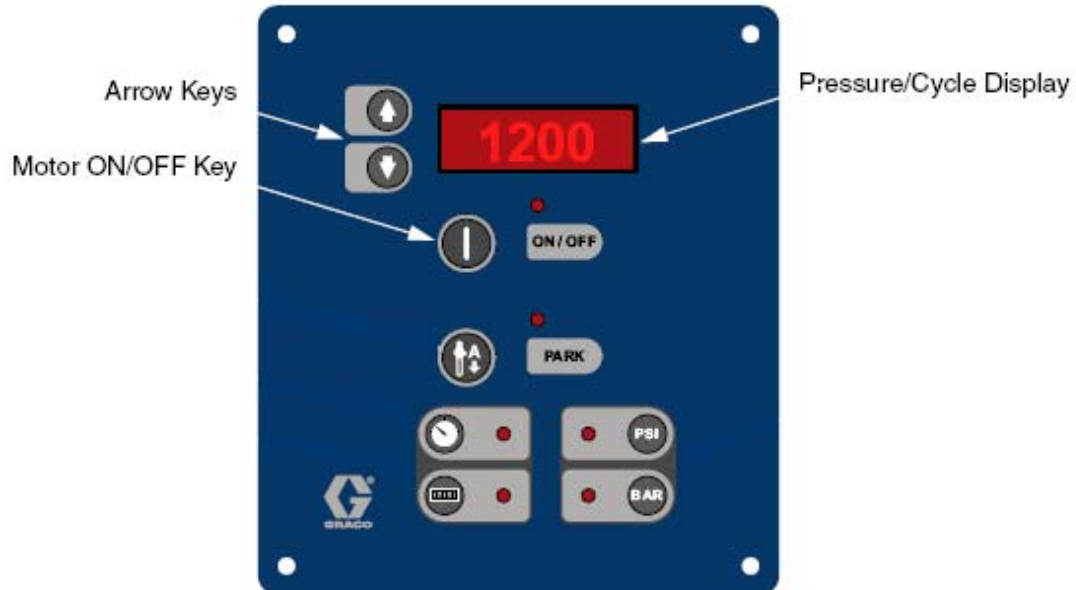

Motor Controls and Indicators

- Check the analog gauges to see which pressure is higher. And then check and see if the pump display pressure matches. If it does, that would indicate that the motor control board is “Seeing” that transducer.
- With the pump still off, use the pressure relief/spray valve to slowly relieve the “higher” side pressure, while watching the digital display and the analog gauges. Once the higher analog gauge drops below the lower analog pressure the pump display should start reading the “new” higher side pressure (because it is now the higher of the two). Then slowly drop the “new” higher side pressure until the digital display stops at the original “higher” side analog gauge reading.

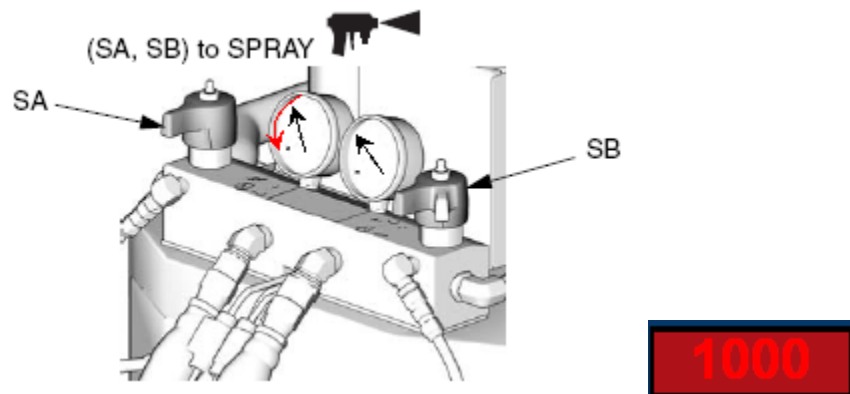

Reactor Error Code Trouble Shooting Guide

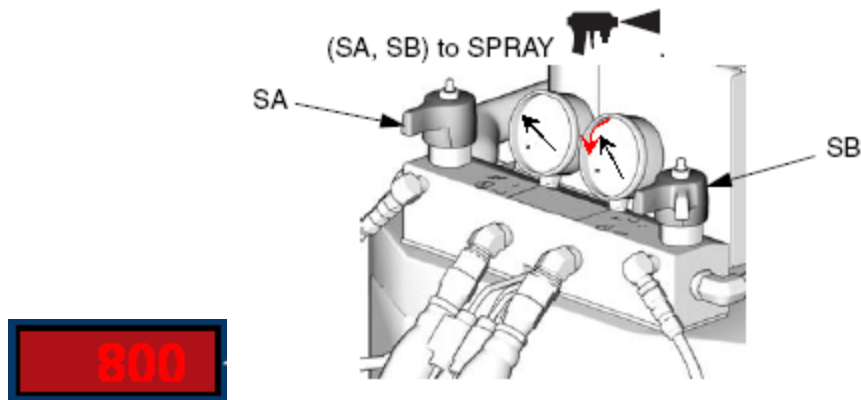

- ✓ The last test is to determine if the pressure transducer has failed or if the socket on the pressure control board has gone bad.
 - Swap the transducer plug-ins on the motor control board. (J3 & J8 for the E-20 & E-XP1 and H series Reactors. J3 & J5 for the E-30 & E-XP2)
 - Repeat above test.
 - If the problem stays with the same side as before then the pressure transducer is bad.
 - If the problem appears to switch over to the other transducer, then the problem is in the motor control board socket.

1b) Pressure imbalance setting is too low for application.

- Adjust setting to higher setting to reduce random nuisance errors.

2) If the gauges are not equal.

Try clearing the error and balancing the pressures using the dump valves.

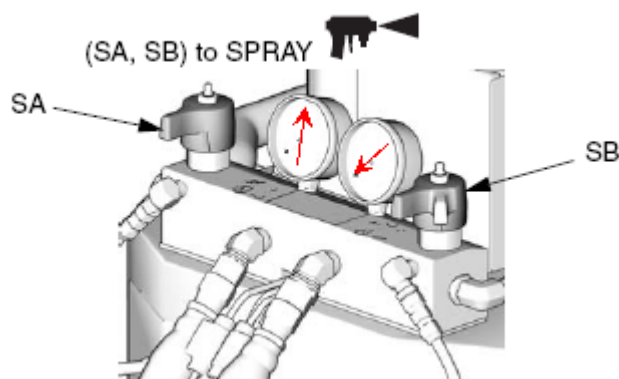

Reactor Error Code Trouble Shooting Guide

- If we can determine what chemical “A” or “B” is coming out of the gun, then we can focus on the missing chemical side. This will immediately save us time by checking the side that is lacking chemical or is the cause of our problem.
- First we need to understand that the restriction of the mix chamber impingement port sizing creates the backpressure that we monitor at the fluid outlet gauges. Think of it as holding your thumb over the end of the garden hose. The more we block, or “restrict” the opening, the greater the backpressure we create.

2a) If “A” (ISO) side is lacking at the gun, and “A” side fluid gauge reading is higher than the “B” side then this is an indication of restriction on the “A” side, anywhere from the gun mix chamber back to the fluid outlet manifold.

Causes:

- Restrictions can include,
 - ✓ blockage in the mix chamber,
 - ✓ gun screen,
 - ✓ whip hose,
 - ✓ hose temperature sensor,
 - ✓ main fluid line,
 - ✓ manifold outlet.
- “A” side chemical is thicker than the “B” due to cold material or primary heater problem.
- “B” side mix chamber port has been increased by wear, reducing the “B” side back pressure causing a resin rich, or too much “B” condition.

2b) If “A” (ISO) side is lacking at the gun, and “A” side fluid gauge reading is lower than the “B” side, this is an indication of a problem from the fluid outlet gauge back to the “A” drum feed supply.

Causes:

- Starving the supply with one of the following.
 - ✓ Supply feed pump malfunction,
 - ✓ Restriction of the feed hose or filter strainer,
 - ✓ Drum is not properly vented due to bung cap in place or desiccant breather clogged.
 - ✓ Debris in the bottom of the drum container,
 - ✓ Dented drum bottom restricting the feed pump inlet,
 - ✓ “A” side proportioner pump has debris or a stuck ball in the inlet or discharge ball check seat area.
 - ✓ If circulating material back to the drum, the pressure relief/spray valve could be leaking, or diverting pressure and material back to the drum.

Reactor Error Code Trouble Shooting Guide

2c) If “B” (RESIN) side is lacking at the gun, and “B” side fluid gauge reading is higher than the “A” side, this is an indication of restriction on the “B” side, anywhere from the gun mix chamber back to the fluid outlet manifold.

Causes:

- Restrictions that can include,
 - ✓ blockage in the, mix chamber,
 - ✓ gun screen,
 - ✓ whip hose,
 - ✓ hose temperature sensor,
 - ✓ main fluid line,
 - ✓ Manifold outlet
- “B” side chemical is thicker than the “A” due to cold material or primary heater problem.
- “A” side port has been increased by wear, reducing the “A” side back pressure causing an ISO rich, or too much “A” condition.

2d) If “B” (RESIN) side is lacking at the gun, and “B” side fluid gauge reading is lower than the “A” side, this is an indication of a problem from the fluid outlet gauge back to the “B” drum feed supply.

Causes:

- Starving the supply with one of the following.
 - ✓ Supply feed pump malfunction,
 - ✓ Restriction of the feed hose or filter strainer,
 - ✓ Drum is not properly vented due to bung cap in place or desiccant breather clogged.
 - ✓ Debris in the bottom of the drum container,
 - ✓ Dented drum bottom restricting the feed pump inlet,
 - ✓ “A” side proportioner pump has debris or a stuck ball in the inlet or discharge ball check seat area.
 - ✓ If circulating material back to the drum, the pressure relief/spray valve could be leaking, or diverting pressure and material back to the drum.

Reactor Error Code Trouble Shooting Guide

E25: High Line Voltage [\(Return to Table Of Contents\)](#)

Cause:

- 1) Supply voltage too high.

Check voltage requirements in technical data section of the manual.
Verify input voltage is correct to motor control board for your system.

E26: Low Line Voltage [\(Return to Table Of Contents\)](#)

Cause:

- 1) Supply voltage too low.

Check voltage requirements in technical data section of the manual.

Verify voltage is correct to the motor control board for your system.

The E-30 and E-XP2 Reactors have a filter between the pump circuit breaker and connection L & N on control board.

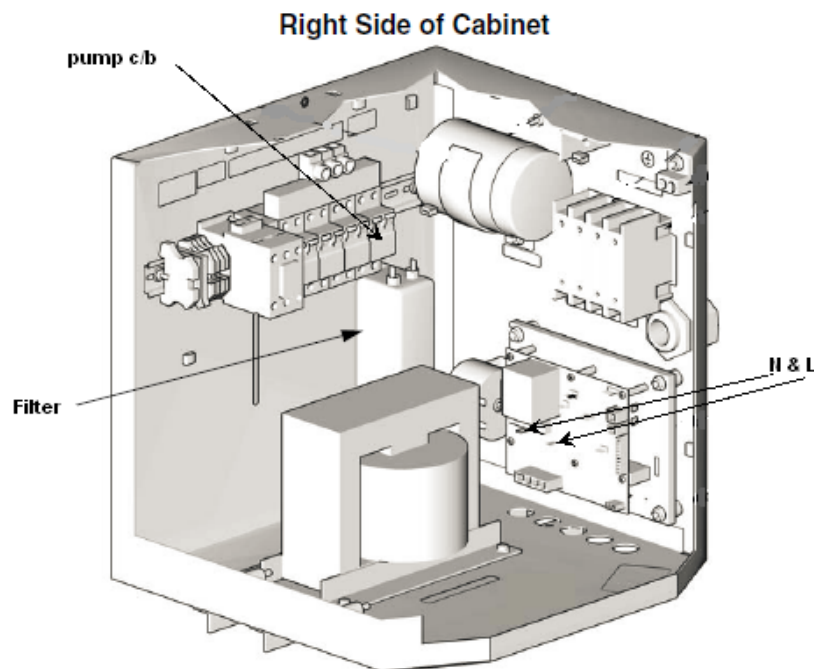

Reactor Error Code Trouble Shooting Guide

E27: High Motor Temperature [\(Return to Table Of Contents\)](#)

Causes:

- 1) **Motor temperature too high.**
 - Reduce fluid pressure, gun mix chamber size, or move the Reactor to a cooler location. Allow one hour for cooling before re-setting.
- 2) **Cooling fan is not operating properly.**
- 3) **Obstruction around the fan area that would cause lack of airflow.**
- 4) **Operating without motor/fan shroud in place.**
- 5) **Operating without the electrical cabinet front cover in place.**
- 6) **The brush wear/over-temp switch wire assembly is not plugged into J7 (E-20/E-XP1) or J6 (E-30/E-XP2) for E-series Reactors and J9 for H-series Reactors of the motor control board.**

If everything appears to be fine and the motor really isn't overheated then see if the problem is with the motor/motor wire assembly, or if the problem is in the motor control board itself.

- With the main power off, unplug the wire harness from J7 (E-20/E-XP1) or J6 (E-30/E-XP2) for E-series Reactors and J9 for H-series Reactors on the motor control board and install a jumper wire on pins 1 & 2. Turn the main power back on.

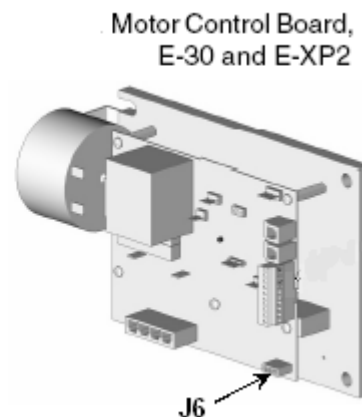
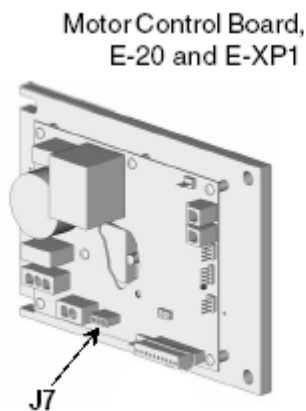

Reactor Error Code Troubleshooting Guide

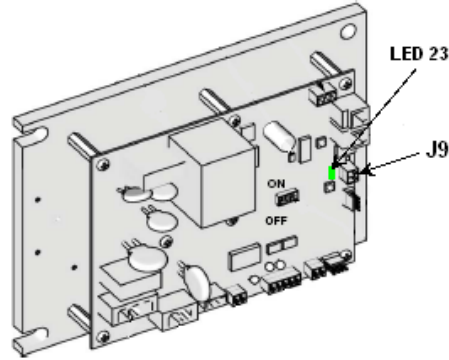

Motor Control Board, H-Series

- **The E27 error should be gone.**
 - If the E27 error is gone and the motor is truly not overheated then the problem is likely in the motor/motor wire harness assembly. You can verify this by measuring the resistance between the 2 yellow wires that go to pins 1 & 2 of the motor o/t connector. If it is an open connection, the thermal overload switch is open or there is a broken wire inside the motor or in the motor harness. On an H-series Reactor motor control board the green LED 23 will be lit if normal state (not over heated) N.C. normally closed.
 - If the E27 error code is still there, then double check to see if pins 1 & 2 are jumpered properly. If they were jumpered properly then it would likely be a problem with in the motor control board.

Reactor Error Code Trouble Shooting Guide

E28: High Motor Current (E-Series Only) [\(Return to Table Of Contents\)](#)

Causes:

- 1) **Failed motor or motor electrical component.**
- 2) **Something in the drive system broken (locked up pump, broken gear, etc.) not allowing the motor to rotate, causing high current.**
- 3) **Possible short in the motor control board.**
- 4) **On E-20/E-XP1 machines only, faulty high pressure switch or loose jumper connection on pin 7 to 10 of connector J10 of the motor control board. See E23 error causes section.**
 - **Check to see if the failure is on the motor control board or if it is within the motor.**
 - Turn the main power switch off.
 - On the motor control board disconnect socket J4 (E-20/E-XP1) J1 (E-30/E-XP2).
 - Turn the main power switch back on.

Did the E28 Error go away?

- If the E28 error did not go away then there is a problem with the motor control board and/or the motor drive system.
- **Replace the motor control board after thoroughly checking the motor drive system.**

(See “Motor and motor drive check procedure” under E-series Reactor E31)

- If the E28 error went away then there is a problem with the motor, or motor drive system.
 - ✓ Check to see if the motor rotates freely. No binding of pump line gear box assembly.
 - ✓ Check to see if the brushes or motor commutator surface is damage.
 - ✓ Check and make sure the voltage going to the motor is good.
 - ✓ Verify the motor will run with a 9 vdc battery.
 - ✓ On E-XP2 and E-30 machines verify capacitor is functional.
 - ✓ Check the three wire (yellow, yellow, orange) motor connector to the motor board. A gentle tug on each wire individually at the connector should ID the loose wire. If a wire pulls out, bend the locking tab on the crimp end, insert the wire until it seats and repeat gentle tug.
- If the above does not resolve the problem, replace the motor.

Reactor Error Code Trouble Shooting Guide

E29: Brush Wear (E-Series Only) [\(Return to Table Of Contents\)](#)

Causes:

- 1) **Normal brush wear, causing the brush sensor to come in contact with the motor commutator.**
 - Replace the brushes p/n-234037.

- 2) **The spade plug inside the motor housing is twisted and making contact with the commutator side of the brush sensor assembly, causing a false alarm.**
 - Follow the orange wire coming from J7 (E-20/E-XP1), or J6 (E-30/E-XP2), up to the spade connector on the motor. Using a flashlight to see check and make sure the spade plug assembly is not making contact with the metal housing of the brush assembly.

- 3) **The yellow brush sensor wire coming out of the brush is routed in-line with the commutator wiring (thick red wire), causing a false alarm.**
 - Reroute the yellow wire coming out of the brush, away from the commutator wiring.

- 4) **The motor control board has failed.**
 - To check:
 - Remove the plug in J7 (E-20/E-XP1), or J6 (E-30/E-XP2). (This will cause an E27 alarm).
 - To remove the E27 alarm, use a jumper wire on the motor control board, across the two pins that the two yellow wires plugged into. Then turn the unit on.
 - The E27 as well as the E29 alarm should be gone. If the E27 alarm is not gone double-check your jumper.
 - If the jumper is installed correctly and the E29 alarm is still there. This would indicate the motor control board is bad. Replace the motor control board.

Reactor Error Code Trouble Shooting Guide

E30: Momentary Loss of Communication [\(Return to Table Of Contents\)](#)

Causes:

- **Communications between the display and the motor control board or the motor control board has been momentarily lost.**

Normally, when communication is lost, the corresponding display will show E99. The corresponding control board will register E30 (The red LED will flash 30 times). If communications are reconnected, the display can show the E30 for a small time (no more than about two seconds). It should not be possible for E30 to be shown continuously, unless there is a loose connection causing the display and the board to continuously loose and regain communication.

- ✓ **Check all wiring between the display and the corresponding control board.**

E31: Motor Drive Error (E-Series Only) [\(Return to Table Of Contents\)](#)

Cause:

1) The motor board has failed. (SCR has shorted)

- The motor control board has malfunctioned, “shorted” and needs to be replaced. Rarely is the control board the cause of this error. Other circumstances such as a motor failure or inadequate input supply voltage lead to this type of motor board failure. Not in all cases will an E31 error code appear. Another symptom of a motor drive failure is that the motor will immediately turn on when input power is applied to the Reactor, running away with no motor control. This is due to the control being shorted sending full voltage to the motor.

• Motor and motor drive check procedure

- After removing machine from the power source, the drive motor will have to be thoroughly check, by pulling the top motor brush and rotating the motor manually with the internal fan blade to inspect the motor commutator all the way around for any evidence of burning or pocking. Continue to rotate the motor until we have completed one pump cycle, up and down to insure there is no mechanical interference in pump lower, or gear drive system. Confirming rotation when connected to a 9vdc battery can then verify the motor is functioning properly. The Reactor machines that have the large Blue capacitor (E-30/E-XP2) will have to have it verified for proper function as well.
- If after confirming a good motor and capacitor, and confirming the input power source is at the required voltage and phase. Replace the drive board. Keep in mind that the power source should not be interrupted prior to powering down the Reactor unit. This would include the generator source running out of fuel.

Reactor Error Code Troubleshooting Guide

Connect the battery to the motor leads that connect to the 2 pin connector shown above

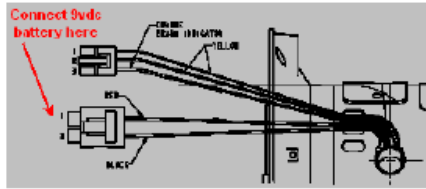

24G881 Motor Control, for E-30 and E-XP2

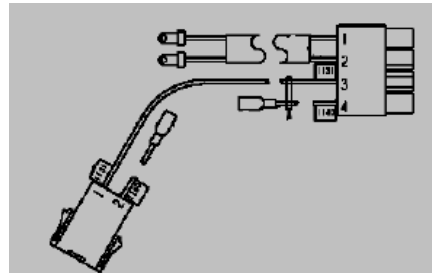
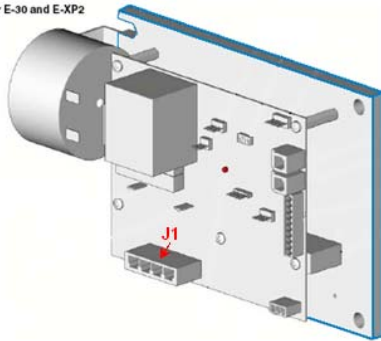

- **Capacitor check procedure**

- Remove the Reactor from power source and wait 15 minutes to allow the capacitor to drain the stored energy through the motor circuit.
Locate the large blue capacitor in the lower cabinet, upper right hand corner.
Perform a general inspection of the capacitor for shape distortion, cracks, or leakage.
Short across the two terminal leads with an insulated handle screwdriver to verify the capacitor is fully discharged. Remove the plug from the motor control board J1 connector.
Set the ohm test meter to a high range of at least 1K ohm. Connect the meter leads black to (-) and red to (+). The meter reading should start at 0 ohms, then move up scale 10K to 20K ohms as the battery from your test meter confirms the capacitor is able to accept a charge.
A reading of constant 0 zero, (short) or OL, (open loop) would indicate a bad capacitor.

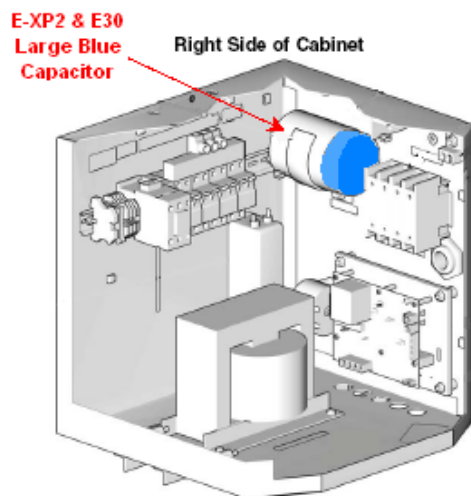

Reactor Error Code Trouble Shooting Guide

[\(Return to Table Of Contents\)](#)

E31: Reversing Switch Failure/High Cycle Rate (H-Series Only)

- Exceeded 65 cpm H-40, H-50, H-XP3
- Exceeded 30 cpm H-25, H-XP2

Causes:

1) Too large a flow rate

- mix chamber too large for system selected
- Fluid pressure too high for mix chamber and system selected.

2) Bad reversing switch/rocker arm assembly

- Check N.O., N.C. contacts on J5 of motor control board.
P3, Black, 1170, N.C.
P2, red, 1160, N.O.
P1, green, 1150, COM
Green LED D19 and green LED D20 light alternately with switch input.

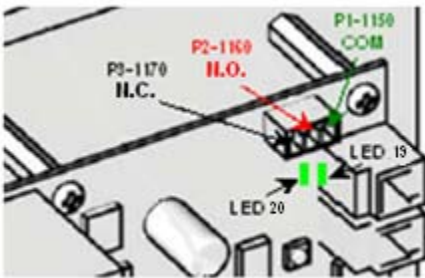

3) Bad connection J5 of motor control board.

- Pull, clean and re-seat input wire connector to J5.

Reactor Error Code Troubleshooting Guide

E99: Loss of Communication [\(Return to Table Of Contents\)](#)

Causes:

- 1) Communications between the display and the motor control board or the temperature control board has been lost.

When communication is lost, the corresponding display will show E99.

- ✓ **Check all wiring between the display and the corresponding control board.**
 - Pay close attention to the wire crimping on plug J13 for each display and motor control boards. And J5/DISPLAY C of temperature control module.
 - Swap the J13 plugs from one display to the other
 - If E99 remains on the same display, replace the Display

Display

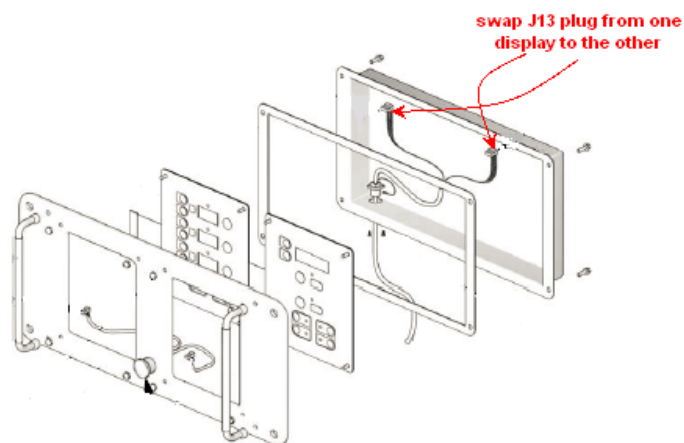

- If E99 moves to other display then reverse the J13 on motor control with J5/DISPLAY C of temperature control module to determine if cable or lower control is the cause.

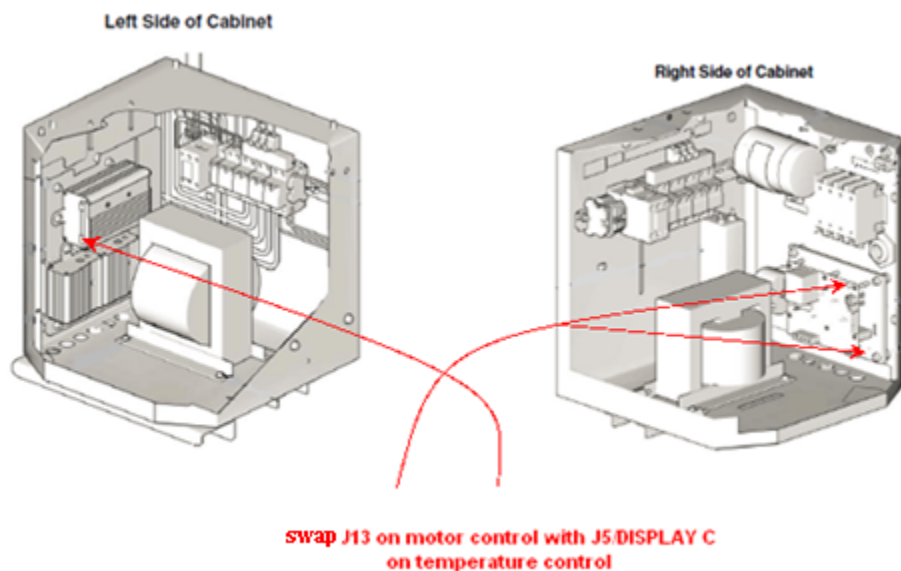

Reactor Error Code Trouble Shooting Guide

Recommend Start-up Technician Tool Set [\(Return to Table Of Contents\)](#)

1. Extech AC/DC True RMS Clamp Meter P/N EX830 or equivalent.

[Extech EX830 1000A True-RMS AC/DC Clamp Meter with IR Thermometer](#)



Measures AC/DC voltage, resistance, frequency, capacitance and more. Peak function captures inrush currents and voltage transients. Zero function for DC current.

2. Pocket Thermometer



Analog Pocket Thermometer w
Magnifying Lens (0 to 220°F)

3. Craftsman Tool Set P/N 37154 or equivalent.



Craftsman 154 pc. Mechanics Tool Set

| Sears Item# 00937154000 | Model# 37154

Overview

Specifications

The 154 piece Mechanics Tool Set includes 93 sockets in 1/4, 3/8 and 1/2 in. drive sizes, both metric and standard sizes, deep and standard depths. The set also includes 12 combination wrenches in metric and standard sizes, 3 quick-release ratchets (each drive), 2 extension bars and 44 specialty tools. The Mechanics Tool Set comes in a convenient and portable briefcase style plastic carrying case.

4. Craftsman Plier Set P/N 45419 or equivalent.



Craftsman 5 pc. Pliers Set

| Sears Item# 00945419000 | Model# 45419

5. Craftsman Punch Set P/N 43167 or equivalent.

Reactor Error Code Trouble Shooting Guide



Craftsman 6 pc. Long Pin Punch Set

| Sears Exclusive. | Sears Item# 00943160000 | Model# 43160

Overview

Specifications

Special Offers

Craftsman punches and chisels feature bright red E-coating for high visibility, double corrosion resistance and easy clean up. Set includes: 5/32 x 7-1/2, 3/16 x 7-1/2, 7/32 x 7-1/2, 1/4 x 7-1/2, 5/16 x 7-1/2, 3/8 x 7-1/2 in. Weight: 1 lb.

6. Chain Wrench 12"
7. Strap Wrench
8. Adjustable Wrenches 6 – 10 – 12"
9. Pipe Wrench 10 – 18"
10. Wire Strippers
11. Ball Peen Hammer 4 – 12 oz
12. Dead Blow Hammer (soft face)