

# WINCO<sup>®</sup> GENERATORS

## WL18000VE-03/B

16,500 RUNNING WATTS

Rugged Steel Design.



B & S Commercial Vanguard Engine.

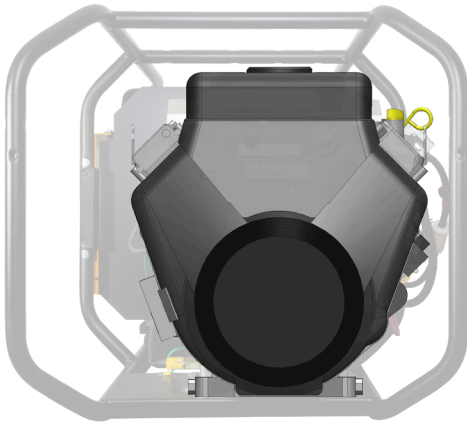

Brushless Industrial Genend.

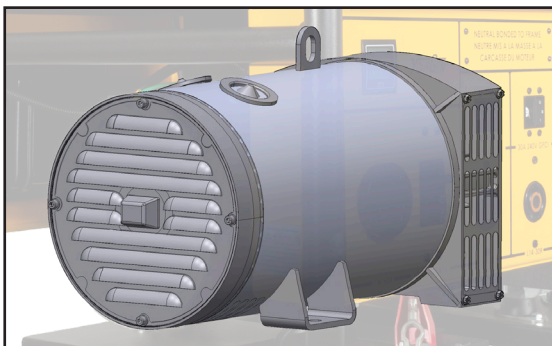

 An American Company.

We produce our products in our 200,000ft<sup>2</sup> facility located in Le Center, Minnesota, equipped with modern engineering, fabrication and assembly capabilities.



## YOURGEN



LED Display

Hours, RPMs, voltage, and frequency readings automatically cycle on the display.

Load Bars

Easily verify the load balance on each leg of the generator end.

Warnings

The LED will flash if any parameter gets outside of normal range. A warning will also be displayed when it is time for an oil change.

Receptacle Panel

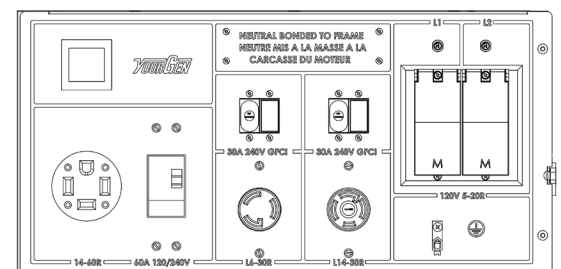

# SPECIFICATIONS

## ENGINE

ENGINE BRAND	BRIGGS & STRATTON
ENGINE MODEL	VANGUARD
ENGINE STARTER	ELECTRIC
ENGINE SPEED	3600 RPM
ENGINE CYLINDERS	V-TWIN
DISPLACEMENT/TYPE	895 CC / OHV
FREQUENCY REGULATION <sup>(1)</sup>	+/- 3%
LOW OIL PROTECTION	STANDARD
RECOMMENDED OIL <sup>(2)</sup>	5W-30
OIL CAPACITY	2.1 QT
FUEL TANK	15 GAL
FUEL GAUGE	YES
FULL LOAD RUN TIME <sup>(3)</sup>	6 HOURS
FUEL CONSUMPTION	GAL/HR
100%	2.49
75%	2.01
50%	1.56
25%	1.25
0%	1.00
BATTERY SIZE <sup>(4)</sup>	BCI GROUP 26 500CCA

NOTES: (1) Steady state frequency regulation. (2) The recommended oil is for normal applications. See operator's manual for the recommended oil for your needs. (3) Run time is estimated. (4) Battery not included.

## SHIPPING

SHIPPING DIMENSIONS (L x W x H)	43.5" x 31" x 37"
SHIP WEIGHT	504 LBS
FREIGHT CLASS	70

## OPTIONAL ACCESSORIES

FOUR-WHEEL DOLLY KIT	WITH FLAT-FREE TIRES
COVER	45" x 32" x 30"
BATTERY	BCI GROUP 26 500 CCA
MAINTENANCE KIT	16200-011

## ELECTRICAL

STARTING WATTS	18,000
RUNNING WATTS	16,500
RUNNING AMPS @ 120 VAC	137.5
RUNNING AMPS @ 240 VAC	68.75
VOLTAGE REGULATION	CAPACITOR +/- 5%
MAIN CIRCUIT BREAKER	60 AMP, 240V VAC
BONDED NEUTRAL	YES
120 VOLT RECEPTACLES	(2) NEMA 5-20 20A (GFCI)
120/240 VOLT RECEPTACLES	(1) 14-60R 60A (1) L14-30 30A (GFCI)
240 VOLT RECEPTACLE	(1) NEMA L6-30 30A (GFCI)
YOURGEN METER	STANDARD

## GENSET

MOTOR STARTING (CODE G)	5 HP
DBA @ 7 METERS	78
TOTAL HARMONIC DISTORTION	< 6%
LIFTING EYE <sup>(1)</sup>	STANDARD
4-WHEEL DOLLY KIT	OPTIONAL
INSULATION	CLASS H
PROTECTIVE ROLL FRAME	1.25" DIA. 14 GA. STEEL
ASSEMBLED IN	USA
EPA APPROVED	YES
CARB APPROVED	NO
CSA APPROVED	NO
UNIT WARRANTY <sup>(2)</sup>	3 YEARS COMMERCIAL

NOTES: (1) Lifting eye shipped loose. (2) For more generator warranty, see operator's manual.

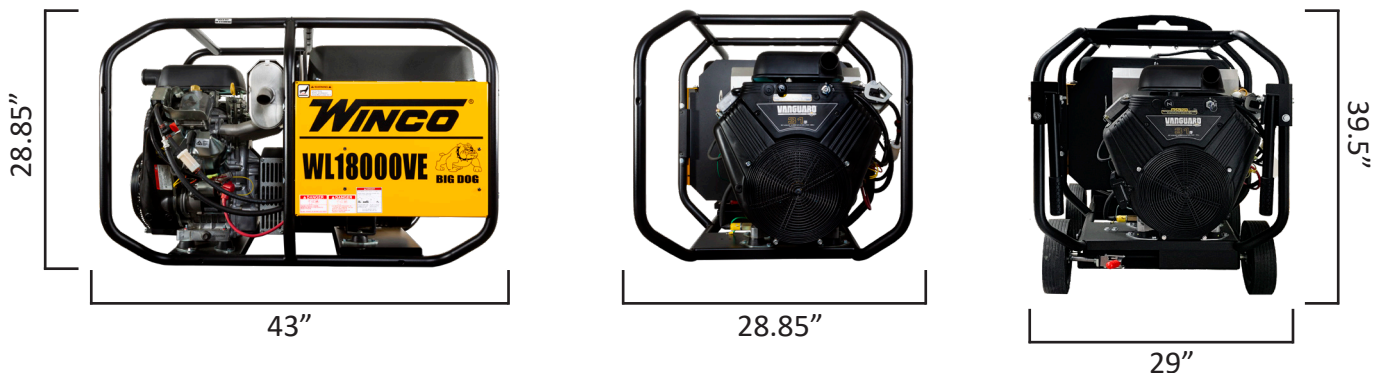

Specifications are subject to change without notice.

