

## ToughTek® S340e Portable Stucco Pump

3A3437F  
EN

Electric sprayer for water-based stucco base, finish coat materials, and Exterior Insulation and Finish Systems (EIFS). For professional use only.  
Not approved for use in explosive atmospheres or hazardous locations.



### Important Safety Instructions

Read all warnings and instructions in this manual and in related manuals. **Save these instructions.**

*For models and related manuals, see page 3.*

*600 psi (4.13 MPa, 41.3 bar) Maximum Fluid Working Pressure*

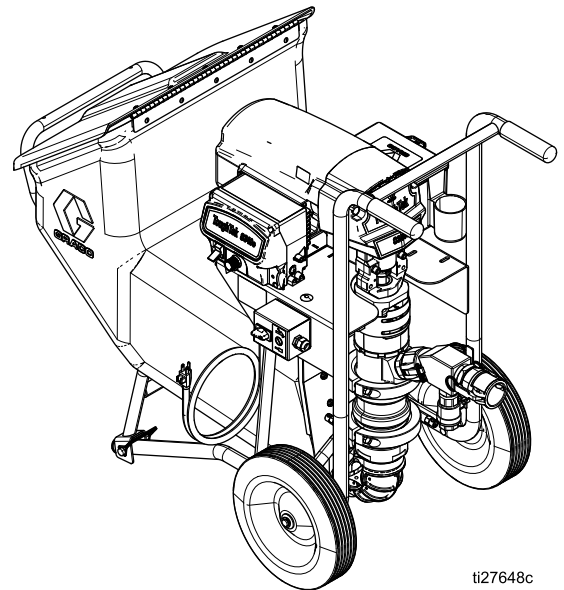

ti27648c

# Contents

Models.....	3	General Adjustments.....	19
Related Manuals .....	3	Spraying Techniques.....	19
Replacement Parts and Accessories.....	4	Material Flow Adjustment .....	19
Warnings .....	6	Air Flow Valve Adjustment.....	19
Component Identification.....	9	Installing Nozzle Retaining Cap.....	19
Overview .....	9	Spray Adjustments (HTXTM Applicator) .....	20
Component Identification Table.....	9	Fluid Drain/Purge Valve .....	21
Motor Power Switch .....	10	Pressure Relief Procedure .....	21
Connect Hoses and Applicator.....	10	Hopper Removal .....	22
Install the Remote Switch (Optional).....	11	Shutdown.....	22
Prime with Material .....	11	Lifting Instructions.....	22
Grounding .....	12	Maintenance .....	23
Power Requirements .....	12	Daily Maintenance .....	23
Setup.....	13	Preventative Maintenance .....	23
Flush .....	14	Corrosion Protection .....	23
Prime with Water .....	16	Water Exposure .....	23
Mix the Material .....	17	Troubleshooting.....	24
Prime with Material .....	17	Mechanical/Fluid Flow.....	24
Spray.....	18	Electrical .....	25
Prevent Pack-out .....	18	Repair.....	27
Before Starting or Stopping Material		Replace Pump Lower .....	27
Flow .....	18	Parts.....	30
Spraying.....	18	Technical Specifications.....	37
Spray Adjustments (Pole Spray Applicator).....	19	Graco Standard Warranty.....	38

## Models

Bare Model	Electric Requirements	Approval	Country	Remote On/Off Switch
25A300	120V, 15A, 50/60 Hz, 1Φ		North America	
25A302				✓
25C610	120V, 15A, 50/60 Hz, 1Φ	CE	United Kingdom	
25C612				✓
25A304†	230V, 10A, 50/60 Hz, 1Φ	CE 	Europe, Asia, Australia	
25A306†				✓

† All 230V pumps include a Europe adapter and Australia adapter cord set.

## Related Manuals

Manuals are available at [www.graco.com](http://www.graco.com).

Component manuals in English:

Manual	Description
3A3438	Pole Spray Applicator
3A3653	HTX Finish Coat Applicator
3A3112	ToughTek® F340e Remote Switch Accessory Kit 17G554
3A3439	ToughTek® S340e Pump Lower Conversion Kit
3A5637	ToughTek® Camlock Mortar Hose
3A4554	ToughTek® Mortar Coupling Hose











# Replacement Parts and Accessories

<b>Accessories</b>	
17G554	KIT, remote switch
17W604	KIT, remote switch, cable (switch and 100 ft cable)
17W829	KIT, remote switch, extension cord (110 ft)
248515	KIT, sponge ball, 30 mm for 25 mm (1.0 in.) dia. hose (Qty. 5)
25A227	KIT, sponge ball, 40 mm for 35 mm (1-3/8 in.) dia. hose (Qty. 5)
17G930	KIT, sponge ball, 60 mm for 50 mm (2 in.) dia. hose (Qty. 5)
114271	STRAP, retaining
240296	KIT, retaining straps, 4-pack
118665	TUBE, grease, Fusion Gun, 4 oz.
248279	TUBE, grease, Fusion Gun, 4 oz., 10-pack
206994	FLUID, TSL 8 oz. bottle
<b>Lower Assembly</b>	
25A233	KIT, rebuild, pump
17G456	KIT, lower, clamp
16W490	KIT, repair, 10-pack, o-ring, cylinder end
25A467	KIT, repair, check balls
17G865	KIT, repair, 3-pack, seal, throat, triple lip
17G864	KIT, pump lower, S340e
25A178	KIT, conversion, F340e to S340e
<b>Inlet</b>	
17G863	KIT, repair, seat, inlet
15H833	BALL, neo/sst core 1.75 in.
<b>Piston</b>	
17G862	KIT, repair, seat, piston
17G798	BALL, neoprene, cs core, 1.625 in.
16W491	KIT, repair, 3-pack, seal, piston
<b>Check Valve</b>	
25A466	KIT, outlet, check valve, S340
17H192	KIT, outlet, seat, o-ring
113082	PACKING, o-ring
17H194	KIT, outlet, check, valve
102973	BALL, metallic
17J712	KIT, F340e, check, retainer
17G866	KIT, fitting, cam, check valve
<b>Rubber Elbow</b>	
17H193	KIT, inlet, elbow
17H196	KIT, elbow, band clamp

<b>Hopper</b>	
17J707	KIT, F340e, hopper with cover
17J709	KIT, F340e, hopper, bracket
17J812	KIT, F340e, stop, bracket
17J710	KIT, F340e, adjustable latch
17J708	KIT, F340e, stop, brackets
<b>Motor and Driver</b>	
17J702	KIT, F340e, MCM, 120V
25C512	KIT, F340e, MCM, 120V, UK
17J755	KIT, F340e, MCM, 230V
17J711	KIT, F340e, motor
17J714	KIT, F340e, finger, guard
17J704	KIT, F340e, front, cover
287282	KIT, repair, shield, motor
17J705	KIT, F340e, tool box

# Warnings

The following warnings are for the setup, use, grounding, maintenance, and repair of this equipment. The exclamation point symbol alerts you to a general warning and the hazard symbols refer to procedure-specific risks. When these symbols appear in the body of this manual or on warning labels, refer back to these Warnings. Product-specific hazard symbols and warnings not covered in this section may appear throughout the body of this manual where applicable.

 <h2 style="margin: 0;">WARNING</h2>	
 	<p><b>ELECTRIC SHOCK HAZARD</b></p> <p>This equipment must be grounded. Improper grounding, setup, or usage of the system can cause electric shock.</p> <ul style="list-style-type: none"> <li>• Turn off and disconnect power cord before servicing equipment.</li> <li>• Connect only to grounded electrical outlets.</li> <li>• Use only 3-wire extension cords.</li> <li>• Ensure ground prongs are intact on power and extension cords.</li> <li>• Do not expose to rain. Store indoors.</li> </ul>
   	<p><b>FIRE AND EXPLOSION HAZARD</b></p> <p>Flammable fumes, such as solvent and paint fumes, in <b>work area</b> can ignite or explode. To help prevent fire and explosion:</p> <ul style="list-style-type: none"> <li>• Use equipment only in well ventilated area.</li> <li>• Eliminate all ignition sources; such as pilot lights, cigarettes, portable electric lamps, and plastic drop cloths (potential static sparking).</li> <li>• Ground all equipment in the work area. See <b>Grounding</b> instructions.</li> <li>• Keep work area free of debris, including solvent, rags and gasoline.</li> <li>• Never spray or flush solvent at high pressure.</li> <li>• Do not plug or unplug power cords, or turn power or light switches on or off when flammable fumes are present.</li> <li>• Use only grounded hoses.</li> <li>• Hold applicator firmly to side of grounded pail when triggering into pail. Do not use pail liners unless they are antistatic or conductive.</li> <li>• <b>Stop operation immediately</b> if static sparking occurs or you feel a shock. Do not use equipment until you identify and correct the problem.</li> <li>• Keep a working fire extinguisher in the work area.</li> </ul>
 	<p><b>MOVING PARTS HAZARD</b></p> <p>Moving parts can pinch, cut or amputate fingers and other body parts.</p> <ul style="list-style-type: none"> <li>• Keep clear of moving parts.</li> <li>• Do not operate equipment with protective guards or covers removed.</li> <li>• Pressurized equipment can start without warning. Before checking, moving, or servicing equipment, follow the <b>Pressure Relief Procedure</b> and disconnect all power sources.</li> </ul>
	<p><b>SUCTION HAZARD</b></p> <p>Powerful suction could cause serious injury.</p> <ul style="list-style-type: none"> <li>• Never place hands near the pump fluid inlet when pump is operating or pressurized.</li> </ul>



# WARNING



## EQUIPMENT MISUSE HAZARD

Misuse can cause death or serious injury.







- Do not operate the unit when fatigued or under the influence of drugs or alcohol.
- Do not exceed the maximum working pressure or temperature rating of the lowest rated system component. See **Technical Data** in all equipment manuals.
- Use fluids and solvents that are compatible with equipment wetted parts. See Technical Data in all equipment manuals. Read fluid and solvent manufacturer's warnings. For complete information about your material, request Safety Data Sheets (SDSs) from distributor or retailer.
- Do not leave the work area while equipment is energized or under pressure.
- Turn off all equipment and follow the **Pressure Relief Procedure** when equipment is not in use.
- Check equipment daily. Repair or replace worn or damaged parts immediately with genuine manufacturer's replacement parts only.
- Do not alter or modify equipment. Alterations or modifications may void agency approvals and create safety hazards.
- Make sure all equipment is rated and approved for the environment in which you are using it.
- Use equipment only for its intended purpose. Call your distributor for information.
- Route hoses and cables away from traffic areas, sharp edges, moving parts, and hot surfaces.
- Do not kink or over bend hoses or use hoses to pull equipment.
- Keep children and animals away from work area.
- Comply with all applicable safety regulations.



## PRESSURIZED ALUMINUM PARTS HAZARD

Use of fluids that are incompatible with aluminum in pressurized equipment can cause serious chemical reaction and equipment rupture. Failure to follow this warning can result in death, serious injury, or property damage.

- Do not use 1,1,1-trichloroethane, methylene chloride, other halogenated hydrocarbon solvents or fluids containing such solvents.
- Do not use chlorine bleach.
- Many other fluids may contain chemicals that can react with aluminum. Contact your material supplier for compatibility.

 <h1 style="margin: 0;">WARNING</h1>	
	<p><b>SKIN INJECTION HAZARD</b></p> <p>High-pressure fluid from dispensing device, hose leaks, or ruptured components will pierce skin. This may look like just a cut, but it is a serious injury that can result in amputation. <b>Get immediate surgical treatment.</b></p> <ul style="list-style-type: none"> <li>• Do not point dispensing device at anyone or at any part of the body.</li> <li>• Do not put your hand over the fluid outlet.</li> <li>• Do not stop or deflect leaks with your hand, body, glove, or rag.</li> <li>• Follow the <b>Pressure Relief Procedure</b> when you stop dispensing and before cleaning, checking, or servicing equipment.</li> <li>• Tighten all fluid connections before operating the equipment.</li> <li>• Check hoses and couplings daily. Replace worn or damaged parts immediately.</li> </ul>
	<p><b>TOXIC FLUID OR FUMES HAZARD</b></p> <p>Toxic fluids or fumes can cause serious injury or death if splashed in the eyes or on skin, inhaled, or swallowed.</p> <ul style="list-style-type: none"> <li>• Read Safety Data Sheets (SDSs) to know the specific hazards of the fluids you are using.</li> <li>• Store hazardous fluid in approved containers, and dispose of it according to applicable guidelines.</li> </ul>
	<p><b>PERSONAL PROTECTIVE EQUIPMENT</b></p> <p>Wear appropriate protective equipment when in the work area to help prevent serious injury, including eye injury, hearing loss, inhalation of toxic fumes, and burns. Protective equipment includes but is not limited to:</p> <ul style="list-style-type: none"> <li>• Protective eyewear, and hearing protection.</li> <li>• Respirators, protective clothing, and gloves as recommended by the fluid and solvent manufacturer.</li> </ul>



# Component Identification

## Overview

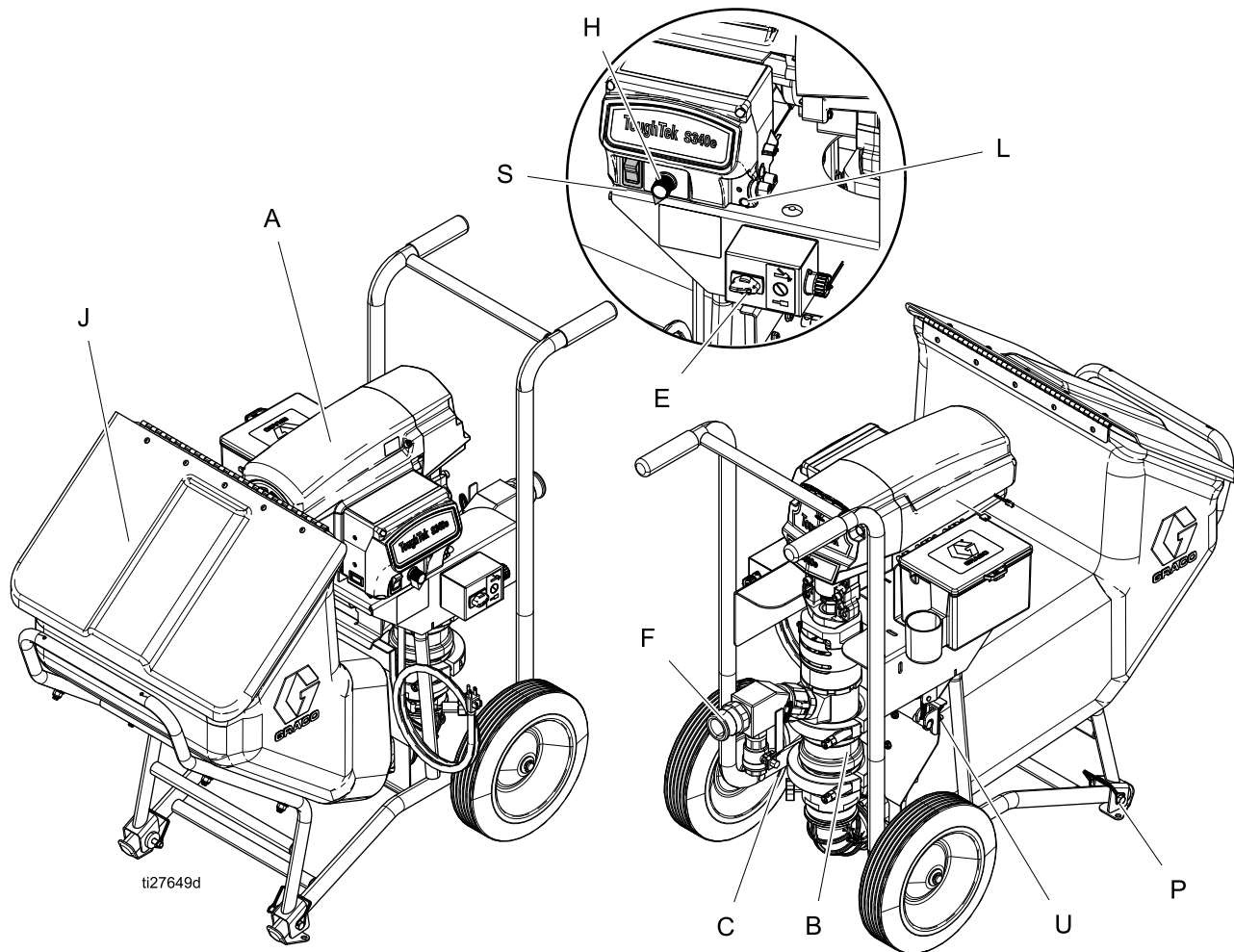

## Component Identification Table

**Key:**

- A Electric Motor
- B Pump Lower
- C Fluid Drain/Purge Valve
- E Remote Pump Control Switch (optional)
- F Fluid Outlet
- H Flow Adjustment Knob
- J Hopper
- L Control Board Status Light

**Key:**

- P Hopper Pin
- S Motor Power Switch
- U Hopper Latch

## Motor Power Switch

The motor power switch (S) must be in the ON for the sprayer to pump material.

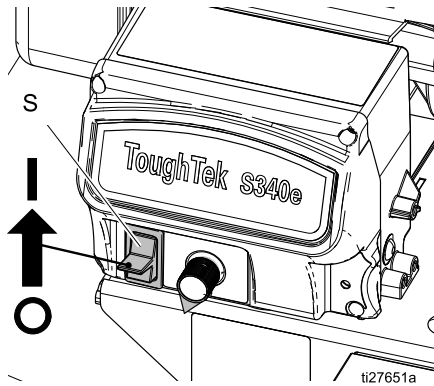

### Motor Power Switch Settings:

OFF	Power is off. The motor will not run.
ON	The motor will run continuously at a speed determined by the flow adjustment knob.

## Connect Hoses and Applicator

- Before connecting hoses/applicator, inspect for damage or wear to both the hose/applicator and cam lock fittings. Fittings should be clean and free of debris, dents, cracks or nicks. The female cam lock fitting must have the gasket installed.
- Always connect hoses from largest diameter to smallest diameter.
- Use a minimum of 25 ft of hose with a working pressure of at least 600 psi (4.1 MPa, 41 bar).
- When fastening cam locks, make sure the pull ring stays to the outside of the cam lock arm to allow for complete and proper sealing of the cam lock. Once installed, use Velcro straps to secure cam locks in place.

## Install the Remote Switch (Optional)

The remote switch is an additional accessory kit and does not come with models 25A300 and 25A304. The kit part number is 17G554. See manual 3A3112 for remote switch installation and replacement.

**NOTE:** Use zip-tie (Z) to install the remote switch to the hose or pole spray applicator (follow the illustrations below). The remote switch will fit on hoses/applicators sized .75 in. up to 1.25 in.

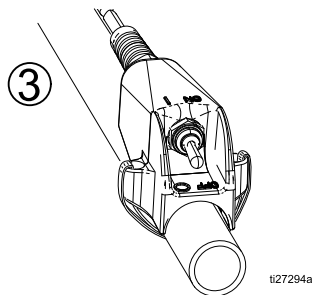
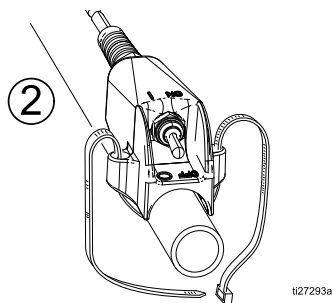
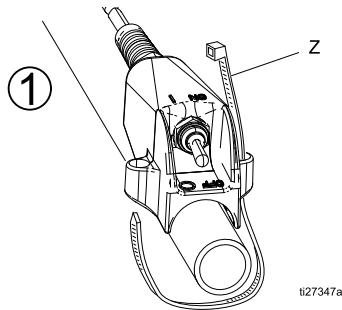

## Prime with Material

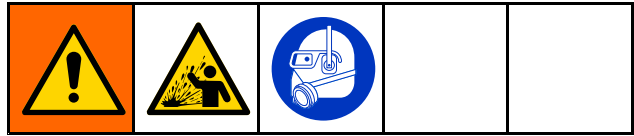

### NOTICE

Loading material into a dry system will cause the material to stick to internal components and cure, causing damage and requiring replacement of those parts. To prevent material curing in system, never load material into a dry system.

The applicator must be removed before priming. Always push out any remaining water into a waste container before circulating material. Always circulate clean material back into the hopper for several cycles before beginning to spray.

1. Prime the system with water. See [Prime with Water, page 16](#).
2. Mix the material. See [Mix the Material, page 17](#).
3. Turn the flow adjustment knob (H) counterclockwise until it stops.
4. Remove the applicator.
5. Fill the clean hopper with material to be sprayed.
6. Place the hose outlet in a waste container.
7. Turn the motor power switch (S) to ON.
8. Turn the flow adjustment knob (H) clockwise slowly to increase pressure until water is purged out and a steady stream of material flows from the applicator.

### NOTICE





To prevent damage to pump seals caused by cavitation, run the pump slowly until the system is primed.

9. To stop dispensing, turn adjustment knob (H) counterclockwise until it stops.
10. Install applicator.

**NOTE:** For EIFS finish coats, before installing the applicator, prime the larger ID hose, then install and prime the transition fitting and whip hose.

11. Recirculate several cycles of material to make sure the material is flowing properly.
12. Turn the flow adjustment knob (H) counterclockwise to stop the pump.
13. Install the air line and a tip onto the applicator (see applicator manual). The system is now primed and ready to spray.

# Grounding

				
<p>The equipment must be grounded to reduce the risk of static sparking and electric shock. Electric or static sparking can cause fumes to ignite or explode. Improper grounding can cause electric shock. Grounding provides an escape wire for the electric current.</p>				

Ground the sprayer by plugging it into an outlet that is properly installed and grounded in accordance with all local codes and ordinances. Do not modify the power cord provided; if it does not fit the outlet, have the proper outlet installed by a qualified electrician.





## Extension Cords

- Use only a 3-wire extension cord that has a grounding plug and a grounding receptacle that accepts the plug on the product.
- Make sure your extension cord is not damaged.
- If an extension cord is necessary, use 12 AWG (2.5 mm<sup>2</sup>) minimum to carry the current that the product draws. An undersized extension cord results in a drop in line voltage, loss of power, and overheating.

**NOTE:** Certain GFCI outlets have been known to trip while using this product.

For 120V units, use a dedicated 15 amp circuit.

# Power Requirements

Model	Required Power Source	Power Cord Connectors	Supplied Local Adapters
230 V, 1 phase, 50/60 Hz	One separate dedicated circuit rated at minimum of 10 A	 One IEC 3-20 C20 Plugs	 Euro CEE7 (Europe)  AS/NZS (Australia)
120V, 50/60 Hz	One separate dedicated circuit rated at minimum of 15 A	 One NEMA 5-15A Plug	

# Setup

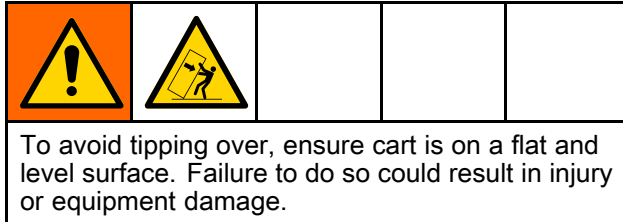

1. Turn the motor power switch (S) to OFF.

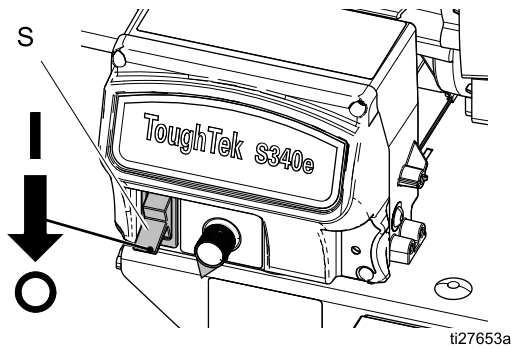

2. Ground sprayer (see [Grounding, page 12](#)). Plug the power cord into a dedicated circuit. See [Power Requirements, page 12](#).
3. Check Throat Seal Liquid (TSL) level in packing nut (D). Fill 1/2 full with TSL.

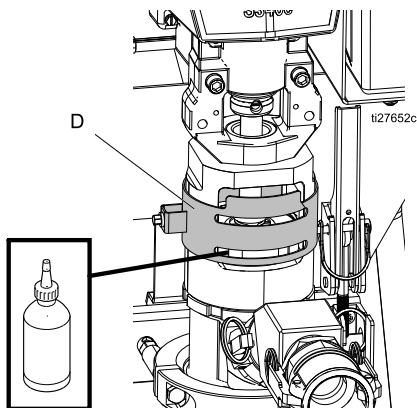

4. Connect air supply to applicator.

5. Attach check valve (optional). Remove fluid outlet assembly (F). Attach check valve (M) to pump fluid outlet. Attach fluid outlet assembly to check valve (M) outlet.

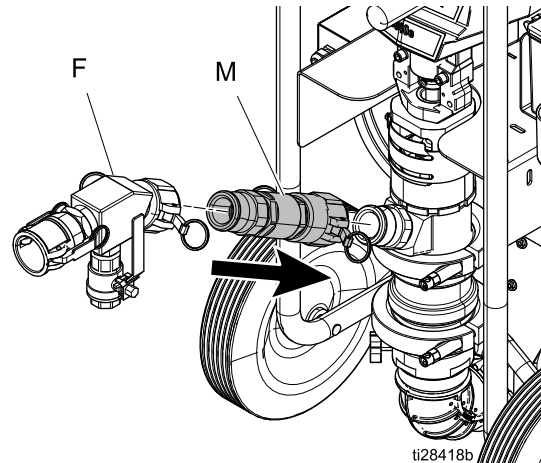

**NOTE:** If a check valve (M) is being used, it must be installed between the fluid outlet assembly (F) and the pump lower to ensure proper operation of the pressure relief valve.

**NOTE:** Check valve (M) is intended for use with low viscosity fluids such as water resistive barriers.

6. Attach hose to applicator fluid inlet and pump fluid outlet (F), then secure Velcro straps (V) around the cam fitting.

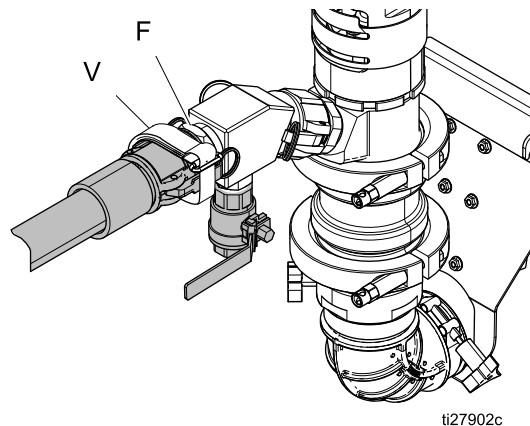

7. Prime the system with water before using (see [Prime with Water, page 16](#)).

# Flush

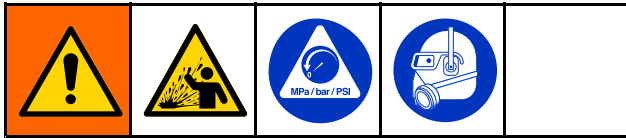

**NOTICE**

Failure to flush prior to material curing in the system will result in damage to system and may require replacement of all system parts in contact with the material.

**NOTICE**

The fluid/drain purge valve must be flushed to prevent material hardening in fluid/drain purge valve. If that is not sufficient, remove, disassemble, and clean the valve then reinstall.

- Flush if the materials in the system are about to reach their cure time.
  - Flush any time the flow rate starts to decrease and there are no clogs in the system, as this is a sign that the material is starting to thicken and cure.
  - Always flush the system at least twice, draining all water between flushes then replacing with clean water.
  - Flush using water only.
1. Perform [Pressure Relief Procedure, page 21](#).
  2. Remove applicator tip and retainer.

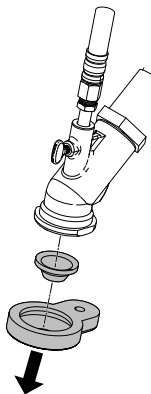

3. Place applicator outlet in a waste container. The waste container must be large enough to hold all dispensed material.

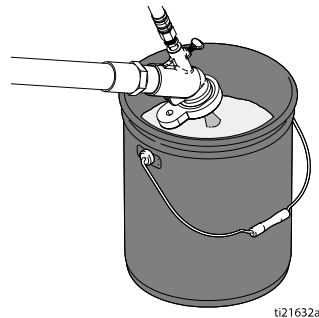

4. Turn motor power switch (S) on.
5. Turn adjustment knob (H) clockwise slowly to increase pressure, until a steady stream flows from gun.
6. When the material level in the hopper is within a few inches of the material inlet at the bottom:
  - a. Scrape the material down the sides of the hopper.
  - b. Fill the hopper with water as the material runs out and continue dispensing.
  - c. Scrub the walls of the hopper with a scrub brush.
7. When water begins to exit the applicator outlet, increase the flow adjustment knob to flush heavy sediments from the system.
8. Once heavy sediment has been flushed, pump the remaining contaminated water out of the hopper.
9. Turn the motor power switch (S) OFF.
10. Remove the hopper and hopper elbow. Clean all residual material, then re-install the elbow and hopper onto the system. See [Hopper Removal, page 22](#).

11. Circulate clean water:
    - a. Fill the system hopper with clean water.
    - b. Turn the motor power switch (S) to ON to begin circulating water. Increase flow and pump for several cycles.
    - c. While pumping, open the fluid drain/purge valve. Allow the water to flush out any material to prevent material hardening in the valve. Once the water appears clean, close the fluid drain/purge valve.
    - d. Turn the motor power switch (S) to OFF.
  12. Remove the applicator and clean/flush separately.
    - a. Make sure all parts are free of residual material.
    - b. Turn on air to make sure air lines are free of obstructions.
  13. Remove the remaining material with a hose clean-out ball:
    - a. Place the hose outlet back in the waste container.
    - b. Remove the hose inlet from the pump outlet and place a hose clean-out ball within the hose inlet. The ball must be wetted down before inserting. If using a 1 in. whip hose, begin with the smallest clean-out ball.
    - c. Reattach the hose to the pump outlet and turn the motor power switch (S) to ON to resume flushing the hose.
    - d. The hose clean-out ball will be pushed out of the hose after several minutes. Once the ball is pushed through the hose, turn the motor power switch (S) to OFF. Repeat until all sediment is removed from the hose.
- NOTICE**

Material left on the throat seal can dry out and damage the seal. Always stop the pump at the bottom of the stroke to avoid damage to the throat seal.
- e. If using a 1 in. whip hose, remove the hose and transition fitting and repeat the process using the large clean-out ball on the remaining hoses. Once the ball is pushed out, pump out the remaining water in the hopper, then reattach the transition fitting and whip hose.
14. Drain remaining water from system:
    - a. Place a drain pan beneath pump lower inlet connection.
    - b. Detach the hopper (see [Hopper Removal, page 22](#)).
    - c. Use a screwdriver to lift the pump lower inlet ball. This will drain the remaining water from the pump lower. When the pump stops draining, release the pump lower inlet ball.
    - d. Disconnect the hose from the pump lower outlet.
    - e. Starting at the pump, raise the hose bundle above your head and slowly move towards the applicator. As you move towards the applicator, the remaining fluid in the hose will drain from the applicator into the bucket.
    - f. Reattach the hopper to the pump.
  15. Dispose of all waste material in accordance with local rules and regulations. See manufacturer's SDSs for additional information.

# Prime with Water

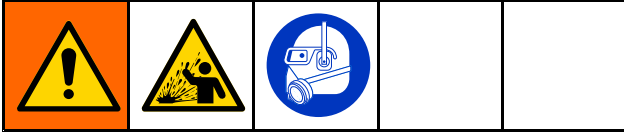

## NOTICE

To prevent material curing in system, never load material into a dry system. Loading material into a dry system will cause the material to stick to internal components and cure, causing damage and requiring replacement of those parts.

1. Fill the hopper with clean water.  
**NOTE:** Some materials require a slicking agent to be run through the hose. Consult the material manufacturer for recommendation.
2. Turn the flow adjustment knob (H) counterclockwise until it stops.
3. Place the applicator into a waste container.
4. Turn the motor power switch (S) to ON.
5. Turn the flow adjustment knob (H) clockwise slowly to increase pressure, until water is purged out.

## NOTICE

To prevent damage to pump seals caused by cavitation, run the pump slowly until the system is primed.

6. Run the clean-out ball(s) to coat the inside of the hoses.
  - a. Remove the applicator from the end of the hose.
  - b. Remove the hose inlet from the pump outlet and place a hose clean-out ball within the hose inlet. The ball must be wetted down before inserting. If using a 1 in. whip hose, begin with the smallest clean-out ball.
  - c. Reattach the hose to the pump outlet and turn the motor power switch (S) to ON to resume flushing the hose.
  - d. The clean-out ball will be pushed out of the hose after several minutes. Once the ball is pushed through the hose, turn the motor power switch (S) to OFF.
  - e. If using a 1 in. whip hose, remove the hose and transition fitting and repeat the process using the large clean-out ball on the remaining hoses. Once the ball is pushed out, pump out the remaining water in the hopper, then reattach the transition fitting and whip hose.
7. Remove the hose inlet from the pump outlet and walk the water out of the hoses.
  - a. Starting at the pump, raise the hose bundle above your head and slowly move towards the applicator end. As you move towards the applicator end, the remaining water will drain from the hoses.
8. Detach the hopper from the pump (see [Hopper Removal, page 22](#)) and properly dispose of any remaining water according to local and state regulations.
9. Use a screwdriver to lift the pump lower inlet ball and drain the remaining water from the pump lower. Once the pump stops draining, release the lower inlet ball.
10. Reattach the hopper to the pump.
11. The system is ready to prime with material.



## Mix the Material

Always follow the material manufacturer's instructions for the material being sprayed. Material must be thoroughly mixed to a smooth consistency before loading it in the hopper.

**NOTE:** For stucco base and base coats, it is recommended to use a standard 8 oz. x 4 in. steel plumb bob (not provided) as a gauge for material pumpability. With the tip of the plumb bob barely touching the material, let the plumb bob drop into the material. If the plumb bob sinks 3/4 of the way or more, the material is a sufficient consistency.

### Managing Material After Mixing:

1. Pay close attention to the work life of the material being used.
2. Only mix the material kits as needed. Do not let mixed material sit longer than necessary.
3. Scrape material down the sides of the hopper as the hopper material level lowers. Do not let older material cure on the walls.
4. To ensure that all material in the hopper is used while fresh, occasionally wait until the hopper is almost empty before refilling.

## Prime with Material

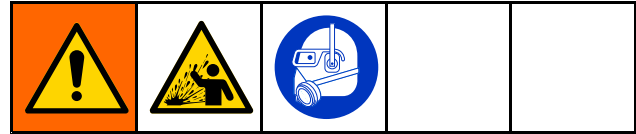

### NOTICE

Loading material into a dry system will cause the material to stick to internal components and cure, causing damage and requiring replacement of those parts. To prevent material curing in system, never load material into a dry system.

The applicator must be removed before priming. Always push out any remaining water into a waste container before circulating material. Always circulate clean material back into the hopper for several cycles before beginning to spray.

1. Prime the system with water. See [Prime with Water, page 16](#).
2. Mix the material. See [Mix the Material, page 17](#).
3. Turn the flow adjustment knob (H) counterclockwise until it stops.
4. Remove the applicator.
5. Fill the clean hopper with material to be sprayed.
6. Place the hose outlet in a waste container.
7. Turn the motor power switch (S) to ON.
8. Turn the flow adjustment knob (H) clockwise slowly to increase pressure until water is purged out and a steady stream of material flows from the applicator.

### NOTICE

To prevent damage to pump seals caused by cavitation, run the pump slowly until the system is primed.

9. To stop dispensing, turn adjustment knob (H) counterclockwise until it stops.
10. Install applicator.

**NOTE:** For EIFS finish coats, before installing the applicator, prime the larger ID hose, then install and prime the transition fitting and whip hose.

11. Recirculate several cycles of material to make sure the material is flowing properly.
12. Turn the flow adjustment knob (H) counterclockwise to stop the pump.
13. Install the air line and a tip onto the applicator (see applicator manual). The system is now primed and ready to spray.

# Spray

## Prevent Pack-out

To avoid “packing out” the pump or hose:

- Use the lowest pressure and largest nozzle size that provides an acceptable spray pattern. This will also result in seals and wear parts lasting much longer.
- Do not use any more fluid hose than is necessary (minimum 25 ft).
- Use an applicator with a rubber tip retainer that will blow off if it plugs (pole gun applications only).

## Before Starting or Stopping Material Flow

Always have the atomizing air turned on at the applicator before and after spraying fluid (see applicator manual).

## Spraying

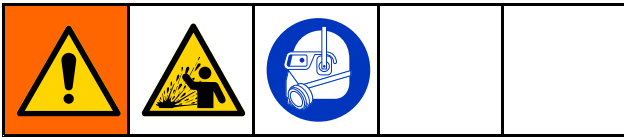

1. [Prime with Water, page 16.](#)
2. [Mix the Material, page 17.](#)
3. [Prime with Material, page 17.](#)

**NOTICE**

- Do not allow pump to run without material in the hopper. It can cause damage to the pump seals.
- Failure to flush prior to material curing in the system will result in damage to system and may require replacement of all system parts in contact with the material.

4. Turn on atomizing air and adjust the air needle valve on the applicator (see applicator manual).

5. Turn the motor power switch (S) to ON.

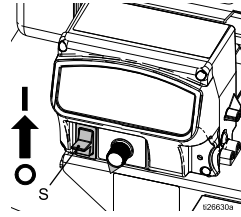

6. Turn flow adjustment knob (H) until desired flow is reached. Turn clockwise to increase flow, counterclockwise to decrease flow.

Typical knob range for stucco:

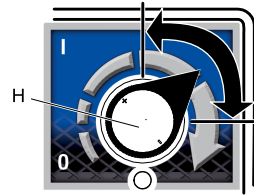

027654a

Typical knob range for EIFS base and finish coats:

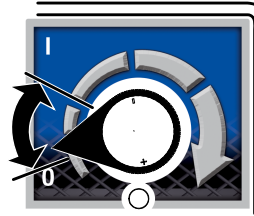

027655a

7. If the system is approaching its cure time or the system will be idle for enough time for material to begin curing in the system, flush the system. See [Flush, page 14.](#)

**NOTICE**

Failure to flush prior to material beginning to cure in the system will result in damage to system and may require replacement of all parts in contact with the material.

# Spray Adjustments (Pole Spray Applicator)

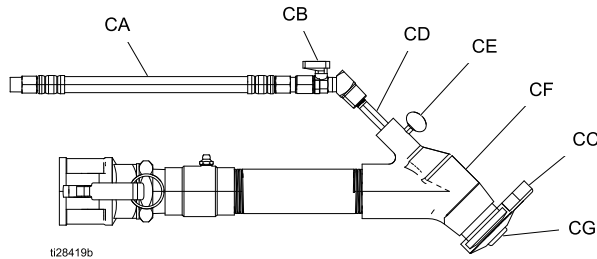

Key:	
CA	Air Assist Air Line
CB	Air Assist Shutoff Ball Valve
CC	Rubber Tip Retainer
CD	Air Needle (adjustable position)
CE	Air Needle Retaining Screw
CF	Fluid Housing
CG	Tip (Nozzle)

**NOTE:** See the Pole Spray Applicator manual for model information.

## General Adjustments

The spray pattern can be adjusted by changing:

- Tip (CG) size
- Fluid and/or air flow
- Air Needle (CD) position

The standard applicator adjustment is to adjust the air needle (CD) slightly behind the fluid tip. Fully open the air ball valve (CB) for the minimum air flow necessary for a good pattern. **NOTE:** Installing the needle (CD) too far forward can reduce the orifice size, stopping material flow.

Air bleeds from the applicator nozzle whenever the applicator air ball valve (CB) is open. Close the valve to stop the air if desired. Otherwise, the air valve can stay open during priming.

Adjusting the spray pattern requires testing to balance the fluid flow and the air to the applicator, and requires the correct tip size.

## Spraying Techniques

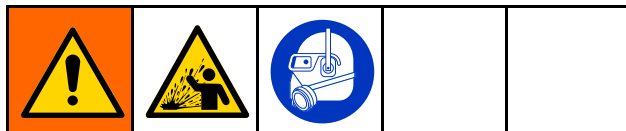

1. Test the spray pattern on cardboard. Hold the applicator 18 – 30 in. (45 – 76 cm) away from the surface. Use this spraying distance for most applications.
2. Adjust fluid flow until material flow is adequate.
3. Adjust the applicator air ball valve (CB) to achieve a uniform round spray pattern.
4. Consider the size of aggregate in the material and the coarseness of the spray pattern. Larger nozzles allow heavier patterns.
5. Overlap each stroke 50%. A circular overlapping pattern may give the best results.

When spraying small confined areas use the air ball valve (CB) and air needle (CD) to make fine adjustments without adjusting the pump.

## Material Flow Adjustment

For a lighter spray pattern, adjust the air needle (CD) closer to the fluid nozzle and/or reduce the fluid flow. For a heavier spray pattern, adjust the air needle (CD) farther back from the fluid tip and/or increase the fluid flow.

**NOTE:** Withdrawing the needle (CD) too far can force air pressure back into the fluid hose, which can slow material flow.

## Air Flow Valve Adjustment

To decrease air flow, turn the air ball valve (CB) clockwise. To increase air flow, turn the air ball valve (CB) counterclockwise.

Check the material and thin it as needed to maintain the proper consistency. The material may thicken as it sits and could slow down application or affect the spray pattern.

Flush and dry the applicator thoroughly at the end of each use. Blow air through the needle after the applicator is clean to ensure that no material is blocking air flow.

## Installing Nozzle Retaining Cap

1. Place the nozzle retaining cap (CC) over the top lip of the applicator housing.
2. Turn the rubber retainer back and forth to make sure it is fully seated.
3. Turn the rubber retainer back and forth to be sure it is fully seated.

**NOTE:** The rubber gasket in the cam and groove inlet fitting and the rubber nozzle retainer should be hand-cleaned and dried after each use.

# Spray Adjustments (HTX™ Applicator)

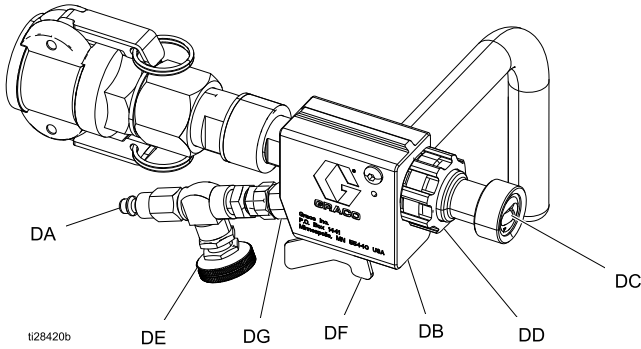

Key:	
DA	Air Assist Air Line
DB	Fluid and Air Manifold
DC	Tip (Nozzle)
DD	Tip Retainer
DE	Air Assist Needle Valve
DF	Air Assist Shut Off Ball Valve
DG	Check Valve

**NOTE:** See the HTX Applicator manual for model information.

## When Spraying

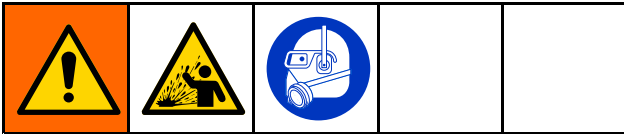

1. Set material flow. See applicator instruction manual for additional information.
2. Spray test pattern.
3. Turn the air knob ON and adjust, and/or select another air nozzle for desired pattern.

**NOTE:** Air continues to flow when the handle is in the OFF position to keep material out of air passages.

## General Adjustments

The spray pattern can be adjusted by changing:

- Tip (DC) size
- Fluid flow
- Air flow, use needle valve (DE)

The standard applicator adjustment is to fully open the air assist valve (DF) while adjusting the needle valve (DE) for the minimum air flow necessary for a good pattern.

Air bleeds from the applicator nozzle whenever the air assist valve (DF) is open. Close the valve to stop the air flow if desired. Otherwise, the air valve can stay open during priming. Air must be on prior to fluid flow.

Adjusting the spray pattern requires testing to balance the fluid flow and the air to the applicator, and requires the correct tip size.

## Air Flow Valve Adjustment

To decrease air flow, turn the valve knob (DE) clockwise. To increase air flow, turn the valve knob (DE) counterclockwise.

Check material and thin as needed to maintain the proper consistency. The material may thicken as it sits and could slow down application or affect the spray pattern.

Flush and dry the applicator thoroughly at the end of each use.

## Spray Techniques

1. Test the spray pattern on cardboard. Hold the applicator 6–18 in. (15–46 cm) from the surface. Use this spraying distance for most applications.
2. Adjust fluid flow until material flow is adequate.
3. Adjust the applicator air assist needle valve to achieve a uniform round spray pattern.
4. Consider the size of the aggregate in the material and the coarseness of the spray pattern. Larger nozzles allow heavier patterns.
5. Overlap each stroke 50%. A circular overlapping pattern may give the best results, and is obtained by grasping the flex-head and swinging the head around as the hose flexes.

When spraying small confined areas use the valve and knob to make fine adjustments without adjusting the pump.

## Cleanup

Thoroughly flush applicator after each work session before fluid begins to cure in the applicator. Remove the check valve and clean all residue from air passages. Store in a dry location. Do not leave the applicator or any parts in water or cleaning solvents.

**NOTE:** The check valve will be damaged if any object is inserted into the valve.

# Fluid Drain/Purge Valve

--	--	--	--	--

To avoid injury from splashing fluid, never open a cam-lock hose or applicator fitting while there is pressure in the fluid line. See [Pressure Relief Procedure, page 21](#).

Open the drain/purge valve (C) to relieve pressure if pump or hose pack-out occurs, or to relieve pressure inside the hose. Close valve when spraying.

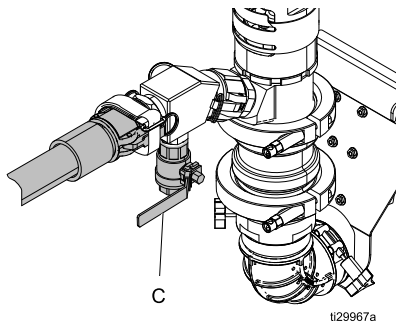

**NOTICE**

To prevent material hardening in fluid drain/purge valve, flush the valve after every time it is used. See [Flush, page 14](#).

# Pressure Relief Procedure

Follow the Pressure Relief Procedure whenever you see this symbol.

--	--	--	--	--

This equipment stays pressurized until pressure is manually relieved. To help prevent serious injury from pressurized fluid, such as splashing fluid, and moving parts, follow the Pressure Relief Procedure when you stop spraying and before cleaning, checking, or servicing the equipment.

To avoid injury from splashing fluid, never open a cam-lock hose or applicator fitting while there is pressure in the fluid line.

1. Turn the flow adjustment knob (H) counterclockwise until it stops.
2. Turn the motor power switch (S) off.
3. Remove the applicator tip and the tip retainer.
4. Hold the applicator firmly against a waste container.

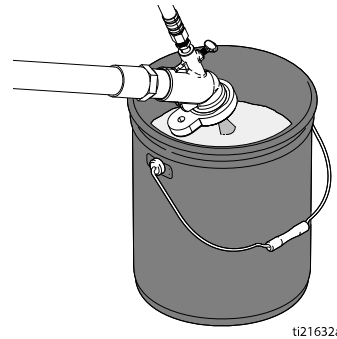

5. Place a waste container beneath the fluid drain/purge valve (C). Slowly open the fluid drain/purge valve (C) at the pump outlet.

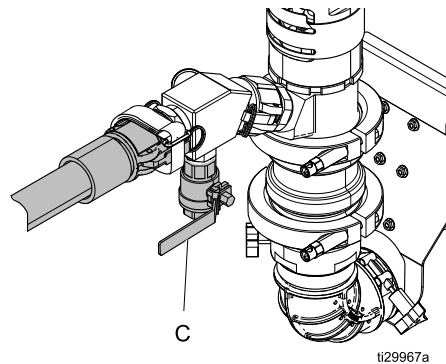



6. If you suspect there is a clog which will not allow pressure to be fully relieved, flush the line through the fluid drain/purge valve (C) using a 3/8 polyurethane tube and water hose.
7. Flush the fluid drain/purge valve (C). See [Flush, page 14](#). Close the fluid drain/purge valve (C).

**NOTICE**

To prevent material hardening in fluid drain/purge valve, flush the valve after every use.

# Hopper Removal

				
To help prevent injury from suction, never place hands near the pump fluid inlet when pump is operating or when hopper is removed.				

The hopper assembly allows easy detachment of the hopper from the pump. To remove the hopper from the pump, perform the following steps:

1. Relieve pressure (see [Pressure Relief Procedure, page 21](#)).
2. Unplug the power cord.
3. Rotate knob (K) counterclockwise to loosen the clamp between the hopper elbow and the lower.

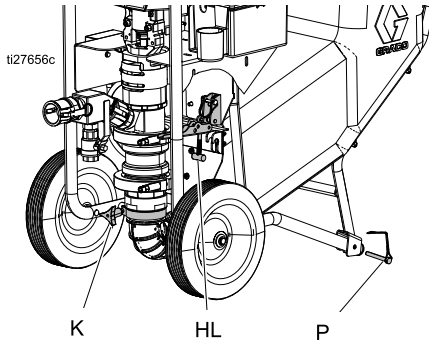



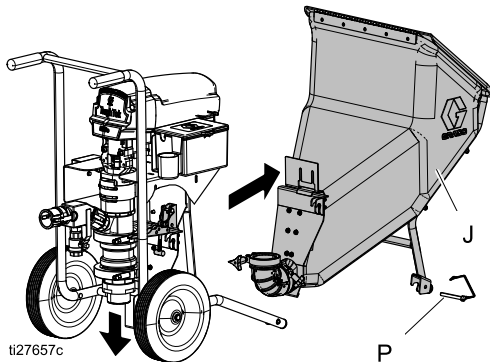

4. Remove the locking pin and pull down the hopper latch (U) on the hopper plate.
- NOTE:** If needed, push down on the hopper elbow to completely disengage from the pump lower.
5. Remove the two hopper pins (P) from the front legs of the cart.
  6. Lift up on the handle and pull the hopper (J) away from the sprayer.



**NOTE:** If the hopper elbow needs to be thoroughly cleaned, rotate knob (K) to loosen the clamp between the elbow and the hopper. Remove and clean the elbow.

**NOTE:** To re-install the hopper, follow the steps above in reverse order.

## Shutdown

				
---	--	---	---	--

### NOTICE

To prevent rust, never leave water or water-based fluid in pump overnight.

To shutdown, flush the system (see [Flush, page 14](#)).

## Lifting Instructions

When lifting the unit, only lift at the points indicated by the arrows below.

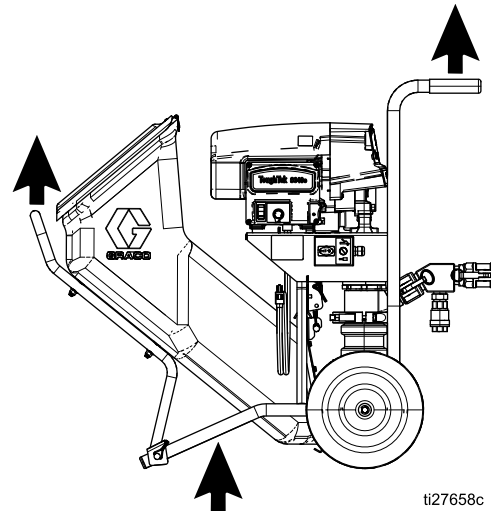

# Maintenance

## Daily Maintenance

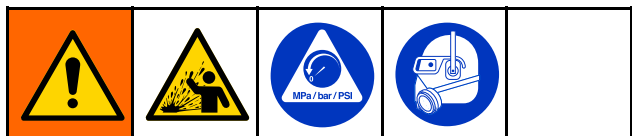

1. Flush the system. See [Flush, page 14](#).
2. Clean hopper with a scrub pad. It is recommended that you clean the outside of the sprayer using a cloth and water.
3. Check hoses, tubes, and couplings for wear or damage. Tighten all fluid connections before each use.
4. Check and replace cam-lock gaskets as needed.

## Preventative Maintenance

The operating conditions of your particular system determine how often maintenance is required. Establish a preventative maintenance schedule by recording when and what kind of maintenance is needed, and then determine a regular schedule for checking your system.

**DAILY:** Check hose for wear and damage, and leaks.

**DAILY:** Check fluid drain/purge valve for proper operation.

**DAILY:** Check level of Throat Seal Liquid (TSL) in displacement pump packing nut/wet cup. Fill nut 1/2 full with TSL. Maintain TSL level to help prevent material buildup on piston rod and premature wear of packings and pump corrosion.

**DAILY:** Check the cam lock connections for damage (dings, nicks, cracks)

**DAILY:** Check the cam lock gasket for damage.

**DAILY (or when changing material):** Break down the pump lower and thoroughly clean and inspect check balls.

**WEEKLY:** Grease swivel fittings on the applicator.

**WEEKLY (or when changing material):** Break down the pump lower and thoroughly clean and inspect all wear components including check balls, piston, o-rings and seats.

## Corrosion Protection

### *NOTICE*

To prevent rust, never leave water or water-based fluid in the pump overnight.

### *NOTICE*

Material left on the throat seal can dry out and damage the seal. Always stop the pump at the bottom of the stroke to avoid damage to the throat seal.

Always flush the pump before the fluid dries on the displacement rod.

## Water Exposure

### *NOTICE*

Exposing the motor and/or control to water can cause damage and possible motor failure. Do not store the pump outside. Do not spray water directly into the motor fan.

# Troubleshooting

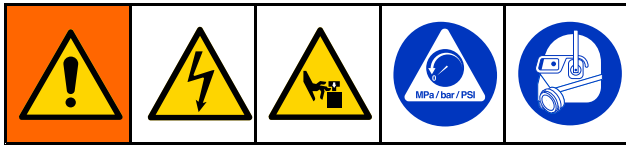

2. Check all possible problems, causes, and solutions listed below before disassembling pump.

For troubleshooting and repair questions, please contact your distributor.

1. Perform [Pressure Relief Procedure](#), page 21.

## Mechanical/Fluid Flow

Problem	Cause	Solution
Displacement pump operates, but output is low on upstroke	Piston ball check not seating properly	Service the piston ball check.
	Piston worn or damaged	Replace the piston.
Displacement pump operates, but output is low on down stroke and/or on both strokes	Piston packings worn or damaged	Replace piston.
	Outlet check valve not seating properly	Clean the check valve.
	Intake valve ball check not seating properly	Service the intake valve ball check.
	Rubber elbow air leak	Tighten clamps on the rubber elbow.
	Fluid hose on the applicator is obstructed	Clean the fluid hose on the applicator.
Material leaks and runs over the side of the wet cup	Loose wet cup	Tighten the wet cup enough to stop leakage.
	Throat seal worn or damaged	Replace the throat seal.
Fluid delivery is low	Applicator tip/gun is dirty or clogged	Clean or replace tip/gun.
	Clamps on hopper elbow are loose	Tighten clamps on the hopper elbow.
	Large pressure drop in fluid hose	Reduce length or increase diameter.
Electric motor does not operate	Power switch is not ON	Turn the power switch ON.
	Tripped circuit breaker	Check circuit breaker at power source. Reset motor switch.
Sprayer does not operate	Fluid hose or applicator obstructed	Clean the hose or application.
	Dried fluid on displacement rod or inlet ball	Clean rod. Always stop pump at bottom of stroke; keep wet cup filled with TSL. Be sure the inlet ball moves freely.
Erratic accelerated speed	Material supply exhausted, clogged suction	Refill the hopper and the prime pump.
	Open or worn piston ball	Clear piston valve; service the piston ball check.
	Open or worn intake valve	Clear or service intake valve.
Cycles or fails to hold pressure at stall	Worn check balls, seats, or piston packing	Service the pump lower.
Poor finish or irregular spray pattern	Inadequate atomizing air pressure	Adjust air needle valve on applicator (see applicator manual).
	Dirty, worn, or damaged spray applicator	Service spray applicator (see applicator manual).
Motor powered but nothing comes out of hose	Pump is packed out with dry or cured material	Disassemble and Clean the pump.
	Hose is packed out with dry or cured material	Try to flush the hose using water hose and/or polyurethane tube.



Problem	Cause	Solution
Material is too thick to push through the hose without packing out	Hose is too restrictive	Thin and mix material thoroughly to a lower viscosity.
		Use a pump system priming fluid (slime). Wet out the system.
		Use a larger diameter hose.
		Thoroughly mix in a pump-aid or performance admixture to the material.

## Electrical

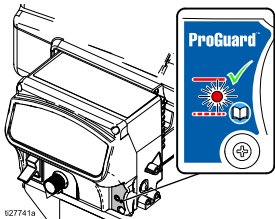
Problem	Cause	Solution
Control board status light blinks 4 times repeatedly 	The control board is detecting multiple voltage surges	Check voltage supply to the sprayer: 1. Turn the motor power switch (S) to OFF and unplug the sprayer. 2. Locate a good voltage supply to prevent damage to electronics.
Control board status light blinks 5 times repeatedly	Check for line obstruction or pack out. Motor is powered but not able to turn.	Open the relief valve to relieve pressure. Remove the obstruction and cycle power off and on. If the problem continues, contact your local distributor.
Control board status light blinks 6 times repeatedly	The motor is overheating	Allow the sprayer to cool. If the sprayer runs when cool, correct the cause of overheating. Keep the sprayer in a cooler location with good ventilation. Make sure the motor air intake is not blocked. If the sprayer still does not run, contact your local distributor.
Control board status light blinks 8 times repeatedly	Incoming voltage is too low for sprayer operation	Check voltage supply to the sprayer: 1. Turn the motor power switch (S) to OFF and unplug the sprayer. 2. Remove other equipment that uses the same circuit. 3. Locate a good voltage supply to avoid damage to electronics.
Control board status light blinks 10 times repeatedly	The control board is overheating	1. Make sure the motor air intake is not blocked. 2. Make sure the fan has not failed. 3. Make sure the control board is properly connected to the back plate and that conductive thermal paste is used on power components. 4. Replace the control board. 5. Replace the motor.
Control board status light blinks 12 times repeatedly	Excessive current protection is enabled	Cycle the power on and off.

Troubleshooting

Problem	Cause	Solution
Control board status light blinks 15 times repeatedly	Connections above the motor may be loose or damaged	<ol style="list-style-type: none"> <li>1. Turn the motor power switch (S) to OFF and unplug the sprayer.</li> <li>2. Remove the motor shroud.</li> <li>3. Disconnect the motor control and inspect for damage at the connectors.</li> <li>4. Reconnect the motor control.</li> <li>5. Turn the motor power switch (S) to ON. If the blinking code continues, replace the motor.</li> </ol>
Control board status light blinks 16 times repeatedly	Check the connections. Check for water in sensor. Control is not receiving motor position sensor signal.	<ol style="list-style-type: none"> <li>1. Turn power OFF.</li> <li>2. Remove the motor shroud.</li> <li>3. Disconnect the motor control and inspect for damage at the connectors.</li> <li>4. Inspect the sensor for water. If the sensor is wet, let it dry for 24 hours.</li> <li>5. Re-install the sensor, motor control connections, and shroud.</li> <li>6. Turn power ON. If the problem continues, replace the motor.</li> </ol>
Control board status light blinks 17 times repeatedly	The sprayer is plugged into the wrong voltage	<ol style="list-style-type: none"> <li>1. Set the motor power switch (S) to OFF and unplug the sprayer.</li> <li>2. Locate a good voltage supply to avoid damage to electronics.</li> </ol>

# Repair

## Replace Pump Lower

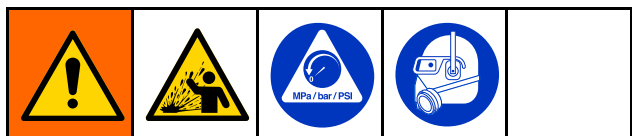

Perform the procedure below to replace the entire pump lower with a new or different pump lower.

1. Perform the [Pressure Relief Procedure](#), page 21.
2. Disconnect the hopper, material hose, and power.
3. Remove outlet fittings (OF) from the pump lower (6a) outlet.
4. Lift retaining spring (6m) and remove pin (6k).
5. Loosen jam nut (19) and unthread the pump lower (6a).
6. Disconnect the piston extension rod (6b) by removing clip (6e) and disassembling the coupler cover (6d) and assembly coupling (6c). The pump lower (6a) should now be separated from all other parts. Replace the pump lower and reinstall on the unit. If pump components need replacing, see [Replace Pump Components](#)

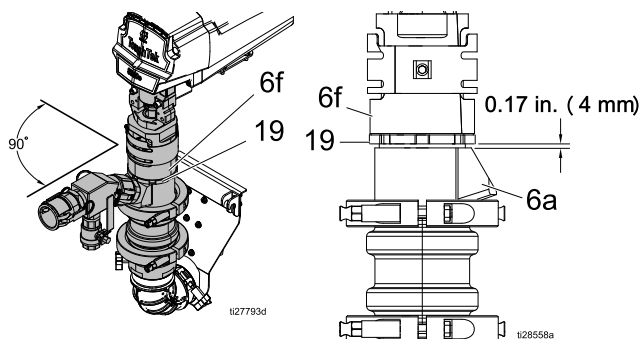

**NOTE:** When reinstalling the pump lower, the jam nut (19) should be threaded on the pump lower until it bottoms out. The pump lower should be threaded completely into the motor adapter (6f) and backed off to the correct orientation position shown above. Once in position, unthread the pump two additional turns and secure the jam nut.

### NOTICE

Failure to assemble the pump lower to the correct depth and orientation can cause damage to the pump. To avoid damage to the pump, follow the **Note** above.

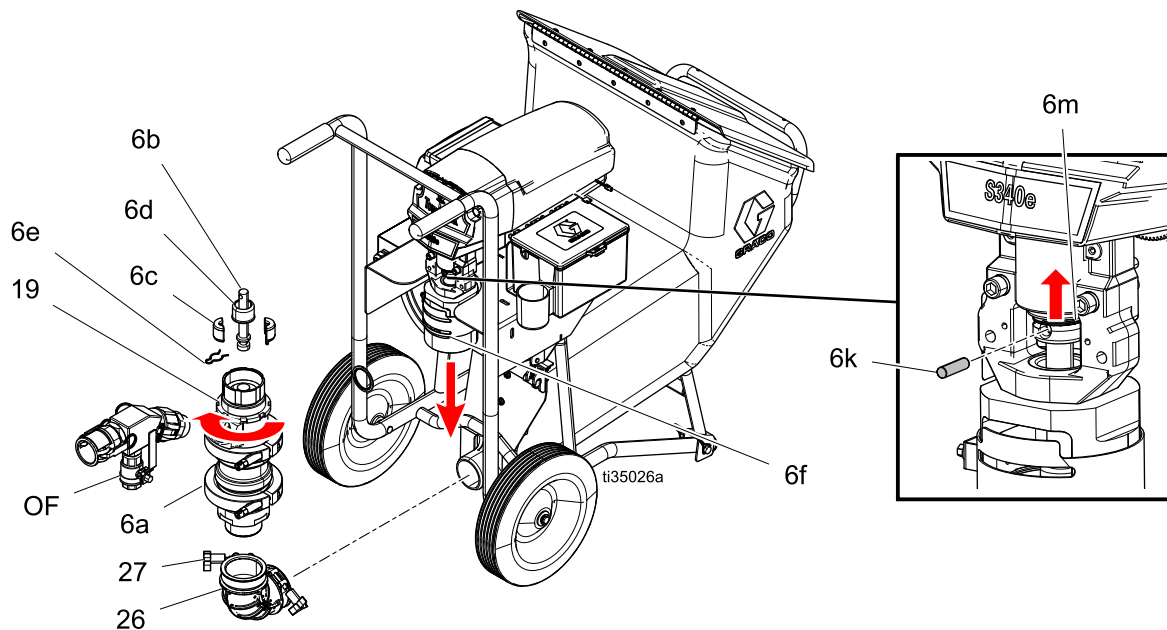

## Replace Pump Components

Remove the pump lower (6a – 17G864) before replacing any pump components.  
For a list of available pump lower kits, see the list on the following page.

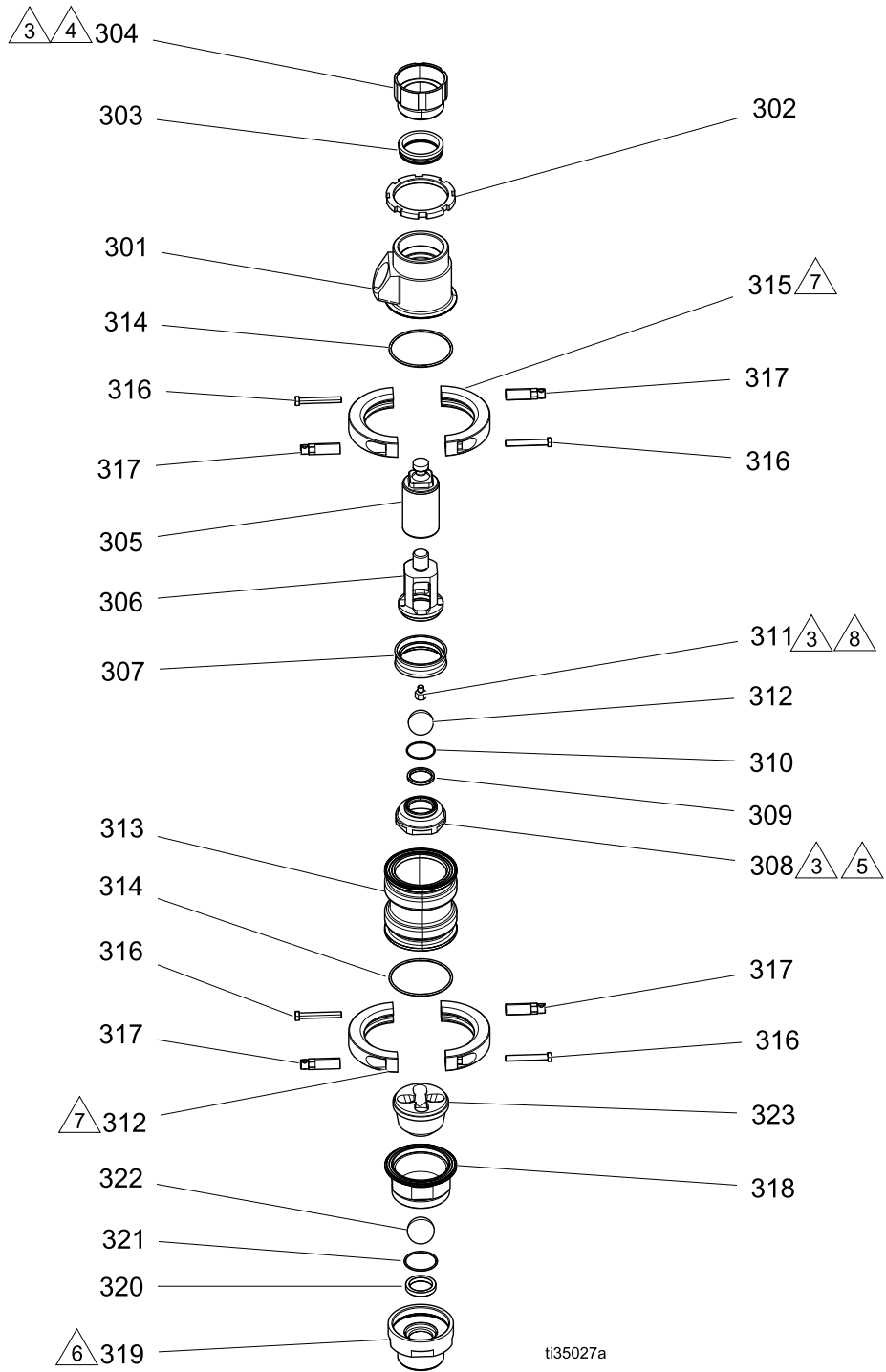

## Pump Components Parts List

Ref.	Part	Description	Qty.	Ref.	Part	Description	Qty.
301	17G220	HOUSING, outlet	1	318	17G226	HOUSING, inlet, ball guide	1
302	17G859	NUT, jam, black	1	319	17G221	HOUSING, inlet	1
303	17G865	KIT, bearing, seal throat, 3-pack	1	320	†	SEA, carbide, valve, inlet	1
304	17G321	NUT, packing, 340e	1	321	†	O-RING, 50 mm x 2.5 mm	1
305	17G331	ROD, short, displacement	1	322	15H833†	BALL, neo/sst core, 1.75 in.	1
306	17G795	GUIDE, ball, piston	1	323	17G793	GUIDE, ball, inlet	1
307	16W491	PACKING, cup, 3-pack	1	† See List of Kits table for more information.			
308	17G794	VALVE, piston	1				
309	†	SEAT, carbide, valve, piston	1	△ <sub>1</sub>	Apply grease lubricant to threads, o-rings and seals.		
310	†	PACKING, o-ring	1	△ <sub>2</sub>	Apply serviceable thread locker to threads.		
311	17G817	STOP, ball, piston	1	△ <sub>3</sub>	Apply anti-seize to threads.		
312	17G798†	BALL, neoprene, cs core, 1.625	1	△ <sub>4</sub>	Torque to 30 +/-5 ft-lb (40 +/- 6.7 N•m).		
313	17G330	CYLINDER, short	1	△ <sub>5</sub>	Torque to 100 +/-5 ft-lb (135 +/- 13.5 N•m).		
314	†	PACKING, o-ring	2	△ <sub>6</sub>	Torque to 200 +/-5 ft-lb (271 +/- 13.5 N•m).		
315	†	CLAMP, 4 in., 1000 psi	2	△ <sub>7</sub>	Orient clamps approximately as shown.		
316	†	SCREW, cap, hex hd	4	△ <sub>8</sub>	Torque to 10 +/-2 ft-lb (13 +/- 2.7 N•m).		
317	†	NUT, extension, 3/8-16	4				

## List of Kits

Kit	Description	Kit Contents
25A233	Pump rebuild kit	303 (1), 307 (1), 310 (1), 312 (1), 314 (2), 321 (1), 322 (1)
17G456	Pump lower clamp kit	315 (1), 316 (2), 317 (2)
17G862	Piston seat and o-ring	309 (1), 310 (1)
17G863	Inlet seat and o-ring	320 (1), 321 (1)
25A467	Check ball repair kit	312 (1), 322 (1)
16W490	Cylinder o-ring kit	314 (10)

# Parts

## S340e Systems

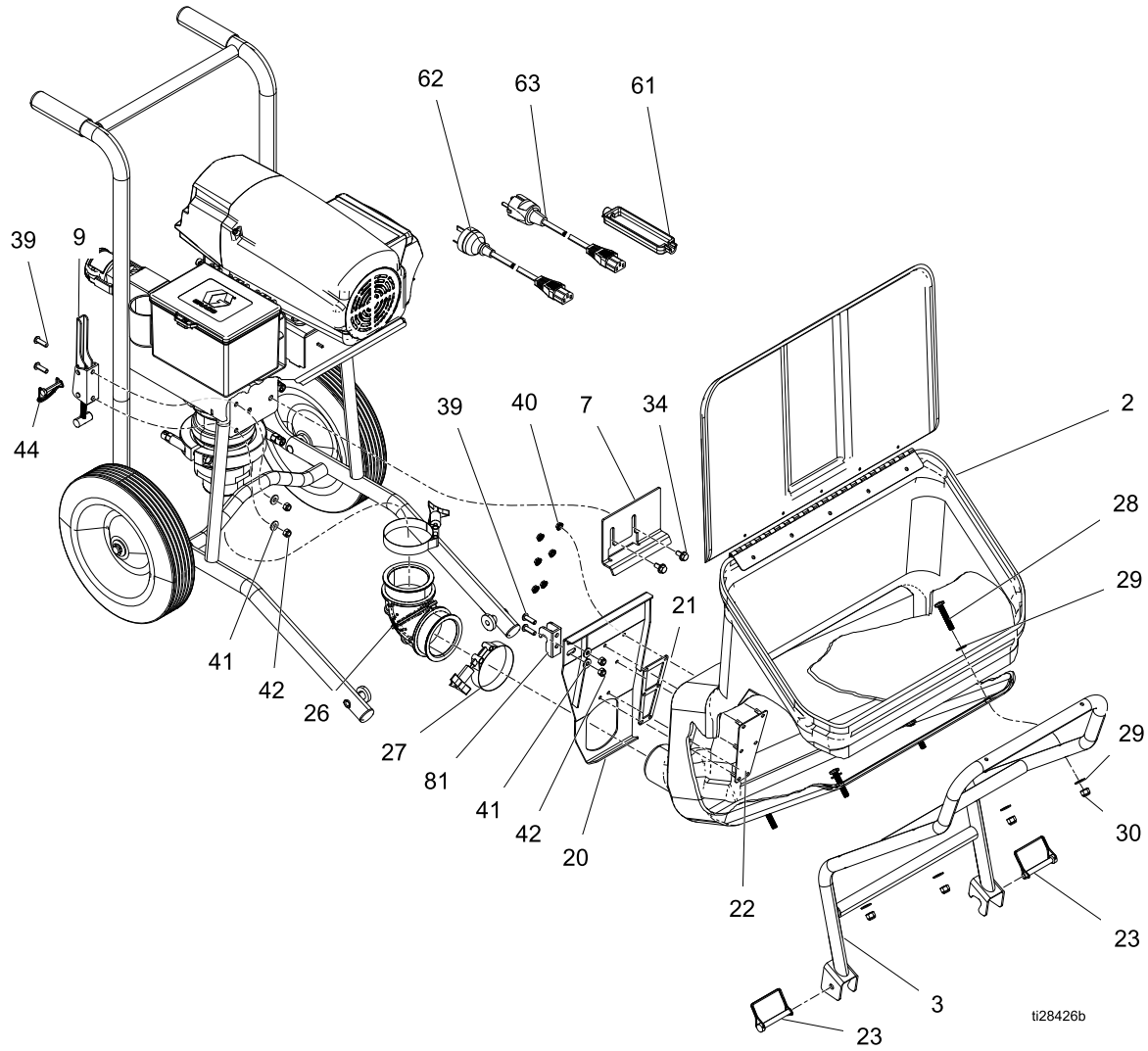

Ref.	Part	Description	Qty.	Ref.	Part	Description	Qty.
2	17J707	HOPPER, 340e, with cover	1	30	101566	NUT, lock	4
3	17J709	BRACKET, 340e, painted, hopper	1	34	-----	SCREW, cap, hex hd	6
7	17J812	BRACKET, stop, adjustable, 340e	1	39	125112	SCREW, cap, btn hd, 5/16 in.	4
9	17J710	LATCH, adjustable	1	40	†	NUT, hex, flange head	6
20	†	BRACKET, stop, hopper	1	41	100527	WASHER, plain	7
21	†	GASKET, hopper mount, 340e	1	42	111040	NUT, lock, insert, nylock, 5/16	7
22	†	PLATE, mount, threaded stud, 340e	1	44	17H025	PIN, 1/4 in. x 1-3/8 in.	1
23	17G368	PIN, 3/8 in.	2	61	195551‡	RETAINER, plug, adapter	1
26	17H193	BOOT, elbow, rubber, 3 in. ID	1	62	242005‡	CORD SET, adapter, Australia	1
27	17H196	CLAMP, hose, t-belt	2	63	242001‡	CORD SET, adapter, Europe	1
28	-----	SCREW, pan head, machine, 3/8-16 x 2 in.	4				
29	100731	WASHER	8				

† *Included in Stop Brackets Kit 17J708.*

‡ *Only included in models 25A304 and 25A306.*

### S340e Systems (continued)

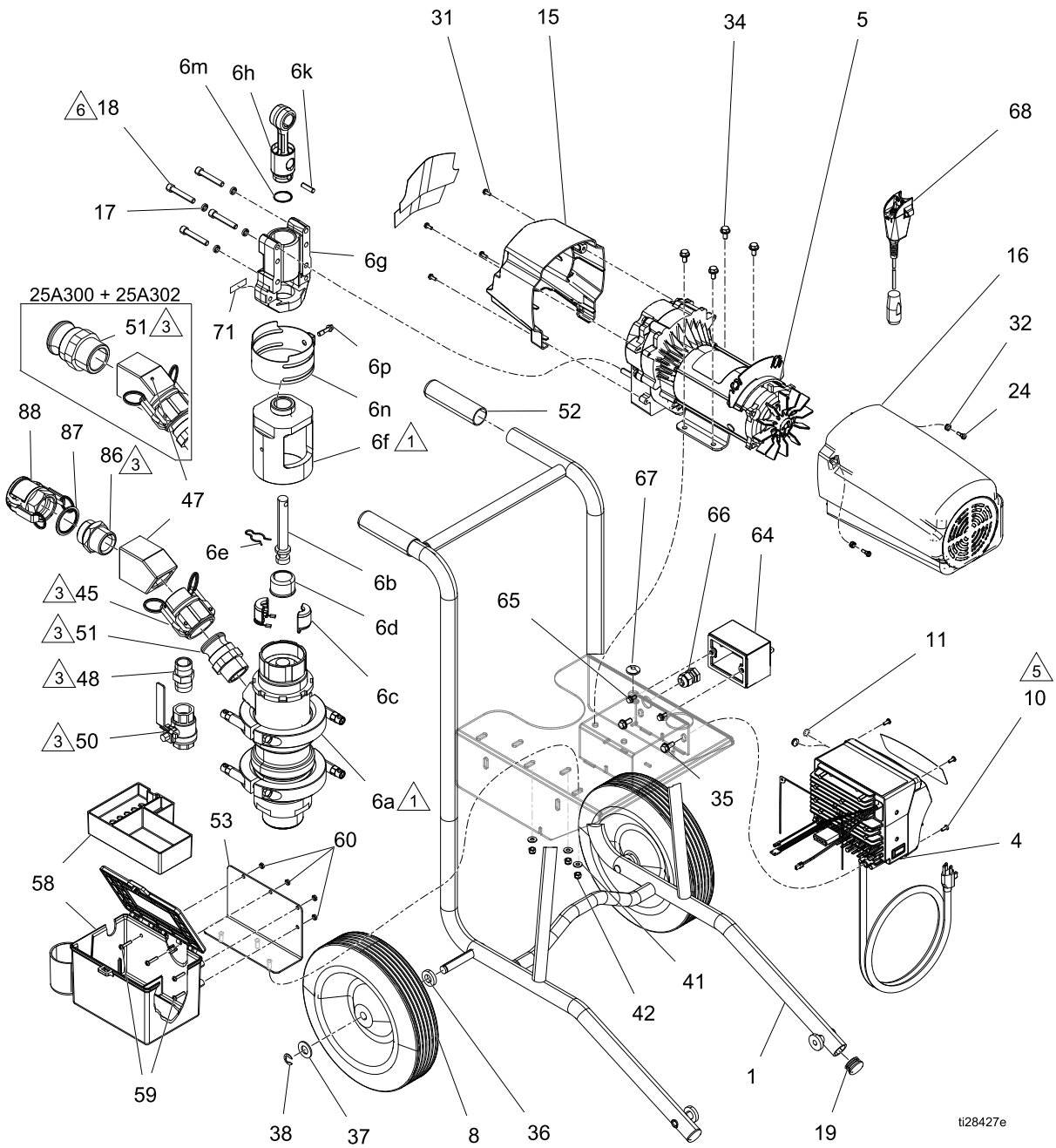

ti28427e



Ref.	Part	Description	Qty.	Ref.	Part	Description	Qty.
1	-----	CART, 340e, painted	1	35	117791	SCREW, cap, tri, lobe	2
4	†	MODULE, 340e, motor control, 120V	1	36	191824	WASHER, space	2
	†	MODULE, 340e, motor control, 120V, UK	1	37	111841	WASHER, plain, 5/8	2
	†	MODULE, 340e, motor control, 230V	1	38	101242	RING, retaining, ext.	2
5	17J711	MOTOR, 340e, pump	1	41	100527	WASHER, plain	7
6a	17G864	PUMP, lower, S340e	1	42	111040	NUT, lock, insert, nylock, 5/16 in.	7
6b	17G283	ROD, extension, piston, 340e	1	45	128758	FITTING, 1.5 cmlk f x 1.50 npt m	1
6c	244819	COUPLING, assembly, 145–290 Xtreme	1	47	17G408	MANIFOLD, outlet, pump	1
6d	197340	COVER, coupler	1	48	17G388	FITTING, hose, 1–11 1/2 npt	1
6e	116407	CLIP, hairpin	1	50	127232	VALVE, ball, 1000 psi, 1 in.	1
6f	17G279	ADAPTER, pump to motor, 340e	1	51	128473	FITTING, 1.5 in. camlock x 1.5 in. nptm	2
6g	-----	HOUSING, bearing	1	52	-----	GRIP, vinyl, gray, 1.25 in.	2
6h	287395	ROD, connecting	1	53	-----	BRACKET, F340e, mounting	1
6k	183210	PIN, str, hdls	1	58	†	TOOL BOX	1
6m	119778	SPRING, retaining	1	59	†	SCREW, mach, pnh	4
6n	†	GUARD, finger, weldment, 340e	1	60	†	NUT, keps, hex hd	4
6p	†	BOLT, special, 5/16–24	1	64	17G554	KIT, remote switch (includes 68)	1
8	17J706	WHEEL, semi pneumatic, offset	2	65	113161	SCREW, flange, hex hd	1
10	16V095	SCREW, mach, pnh, torx, self tapping	4	66	114421	BUSHING, strain relief	1
11*	17H175	PLUG, round	1	67	128596	GROMMET, 5/16 in. ID x 1 in. OD	1
11**	-----	GROMMET, 3/16 in. ID x 9/16 in. OD	1	68	17W604	MODULE, remote, ON/OFF	1
12	-----	WIRE, jumper, remote	1	86	-----	ADAPTER, 1.5 m npt x 1.5 m bspp	1
15	†	COVER, front, plastic, painted	1	87	17N566	SEAL, 1.5 in. bspp	1
16	†	SHIELD, motor, painted	1	88	17N891	COUPLING, mortar, female, 35 mm x 1.5 f bspp	1
17	106115	WASHER, lock (hi collar)	4				
18	114666	SCREW, cap, socket head	4				
19	-----	PLUG, tube	2				
24	119250	SCREW, shoulder	2				
31	118444	SCREW, mach, slot, hex wash hd	4				
32	276980	GROMMET, cover	2				
34	-----	SCREW, cap, hex hd	6				

\* Only included in models 25A300, 25C610, and 25A304.

\*\* Only included in 25A302, 25A306, 25C612.

†See List of Kits table.

① Apply lubricant grease to threads.

③ Apply pipe sealant to threads.

⑤ Torque to 40–45 in-lb (4.5–5.0 N•m).

⑥ Torque to 25 +/-5 ft-lb (33.8 +/- 6.7 N•m).

## List of Kits

Kit	Description	Kit Contents: Ref. # (Qty.)
17J702	120V motor control module kit	4 (1), 10 (4), S340e Label (1), F340e Label (1)
25C512	120V UK motor control module kit	4 (1), 10 (4), S340e Label (1), F340e Label (1)
17J755	230V motor control module kit	4 (1), 10 (4), S340e Label (1), F340e Label (1)
17J714	340e finger guard kit	6n (1), 6p (1)
17J704	Front cover kit	15 (1), 31 (4), S340e Label (1), F340e Label (1)
287282	Motor shield kit	16 (1), 24 (2), 32 (2)
17G554	Remote switch accessory kit	64 (1), 65 (1), 66 (1), 67 (1), 68 (1)
17J705	Tool box kit	58 (1), 59 (4), 60 (4)
17N875	35 mm x 1.5 npfm adapter kit	86 (1), 87 (1), 88 (1)

# Driver and Motor

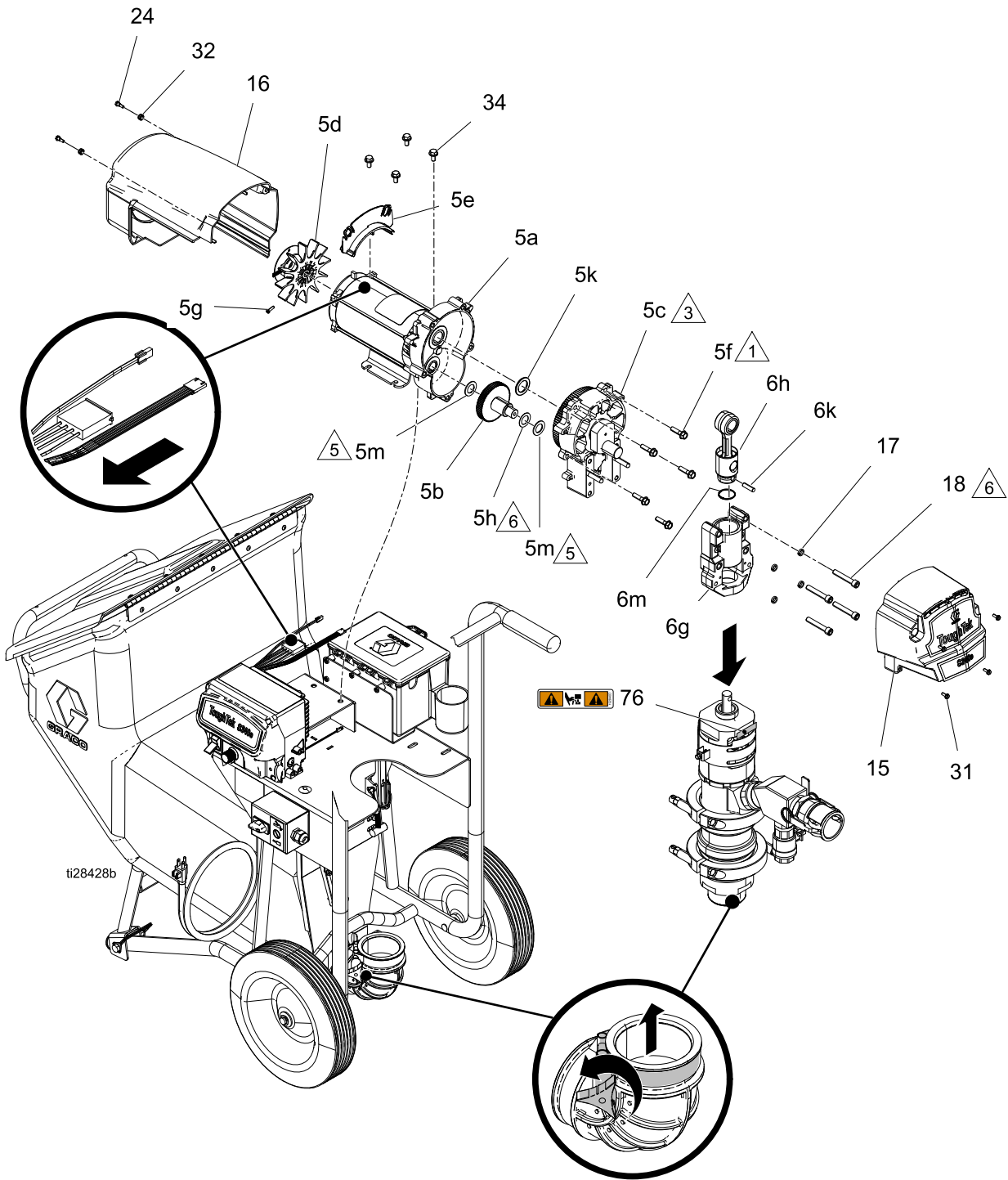

Ref.	Part	Description	Qty.	Ref.	Part	Description	Qty.
5a	-----	MOTOR, electric	1	17	106115	WASHER, lock (hi collar)	4
5b	-----	GEAR, combination	1	18	114666	SCREW, cap, socket head	4
5c	-----	HOUSING, drive	1	24	119250	SCREW, shoulder	2
5d	15D088	FAN, motor	1	31	118444	SCREW, mach, slot, hex wash hd	4
5e	278075	BRACKET, wire	1	32	276980	GROMMET, cover	2
5f	15C753	SCREW, mach, hex wash hd	5	34	-----	SCREW, cap, hex hd	6
5g	115477	SCREW, mach, torx pan hd	1	76▲	192840	LABEL, warning	1
5h	114699	WASHER, thrust	1				
5k	116192	WASHER, thrust	1				
5m	114672	WASHER, thrust	2				
6g	-----	HOUSING, bearing	1				
6h	287395	ROD, connecting	1				
6k	183210	PIN, str, hdls	1				
6m	119778	SPRING, retaining	1				
15†	-----	COVER, front, plastic, painted	1				
16†	-----	SHIELD, motor, painted	1				

▲ Replacement Danger and Warning labels, tags, and cards are available at no cost.

† See List of Kits table.

1 Torque to 190-210 in-lb (21.4-23.7 N•m).

3 Apply lubricant to all gear teeth proportionally.

5 Copper colored washer.

6 Steel colored washer.

### List of Kits

Kit	Description	Kit Contents: Ref. # (Qty.)
17J711	F340e pump motor	5 (1) Includes 5a-5h, 5k, 5m
17J704	Front cover kit	15 (1), 31 (4), S340e Label (1), F340e label (1)
287282	Motor shield kit	16 (1), 24 (2), 32 (2)

## Control Box

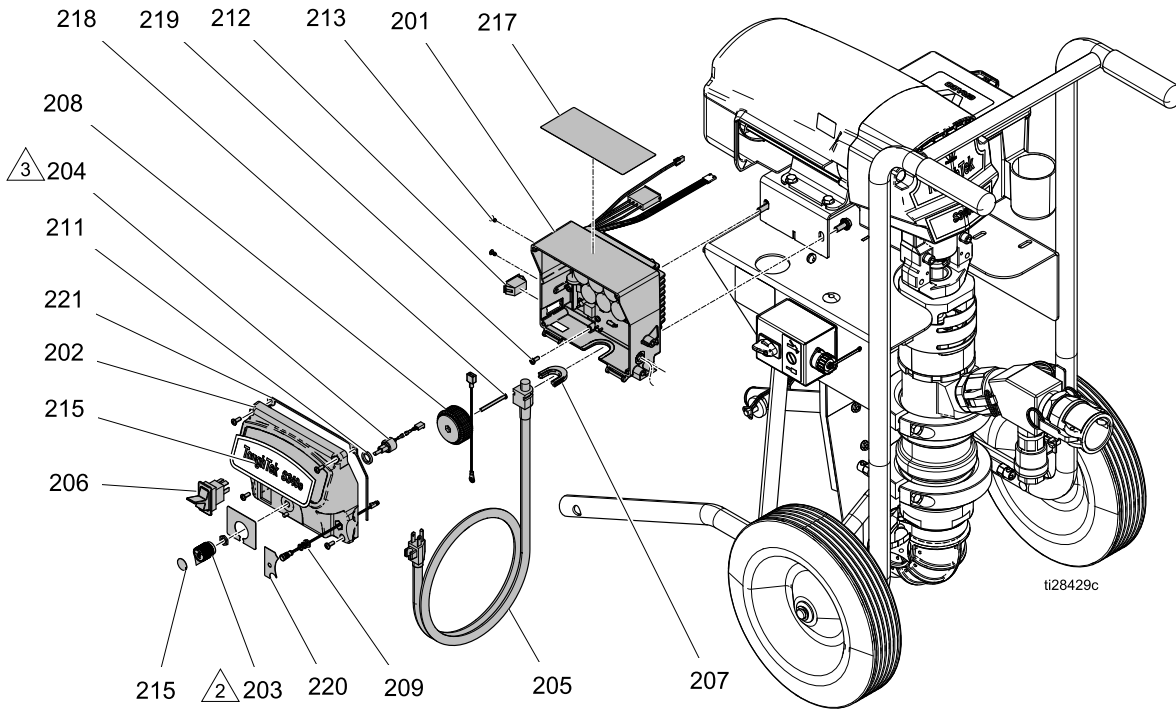

Ref.	Part	Description	Qty.	Ref.	Part	Description	Qty.
201	-----	CONTROL, board, 50 amp	1	213	-----	PLUG, nylon	2
202	-----	COVER, control, ultra, std	1	215	-----	LABEL	1
203	116167	KNOB, potentiometer	1	216	16Y786	LABEL, control, elec, std	1
204	256219	POTENTIOMETER, assembly	1	217▲	16T784	LABEL, warning, EN/FR/ES	1
205	15H064	CORD, power	1	218	16U215	SCREW, phillips, pan hd, plastite	1
206	15D527	SWITCH, rocker, 240V	1	219	114391	SCREW, grounding	1
207	16T547	ADAPTER, cord	1	220	-----	LABEL, control, F340e, Proguard	1
208	-----	COIL, filter	1	221	-----	GASKET, housing, motor, control, F340e	1
209	16Z019	HARNESS, wiring, with light	1				
211	15C973	GASKET	1				
212	16T483	PLUG, hole, switch	1				

△<sub>2</sub> Torque to 10–15 in-lb (1.1–1.7 N•m).

△<sub>3</sub> Torque to 30–35 in-lb (3.3–3.9 N•m).

▲ Replacement Danger and Warning labels, tags, and cards are available at no cost.

**NOTE:** All Control Box Parts listed above are included in both the 120V Motor Control Module Kit (17J702) and 230V Motor Control Module Kit (17J755).

# Technical Specifications

<b>ToughTek S340e Sprayer</b>		
	<b>U.S.</b>	<b>Metric</b>
Maximum Fluid Working Pressure	600 psi	4.1 MPa, 41 Bar
Stroke Length	2.25 in.	57 mm
Maximum pump speed (Do not exceed maximum recommended speed of fluid pump to prevent premature pump wear)	150 cycles per minute	
Weight (dry)	210 lb	95 kg
Wetted Parts	Stainless steel, plated steel, carbide, urethane, PTFE, UHMWPE, LLDPE, aluminum, neoprene	
Fluid inlet Size	3.0 in.	7.6 cm
Fluid Outlet Size	1.5 in. npt(f) with 35 mm female mortar coupling North American systems: 1.5 in. npt(f) with 1.5 in. male camlock	
<b>Power Requirements</b>		
120 V Models	120 VAC, single phase, 50/60 Hz	
230 V Models	230 VAC, single phase, 50/60 Hz	
<b>Hose Requirements</b>		
Minimum Pressure	600 psi	4.1 MPa, 41 Bar
Minimum Hose Diameter	1.0 in.	2.5 cm
Minimum Hose Length	25 ft	7.6 m
<b>Power Requirements</b>		
120 V Models	1 phase, 50/60 Hz	
230 V Models	1 phase, 50/60 Hz	
<b>Noise Level</b>		
Sound Power	90.4 dBa*	
Sound Pressure	80.5 dBa*	
*per ISO 3744; measured at 3.1 ft		

# Graco Standard Warranty

Graco warrants all equipment referenced in this document which is manufactured by Graco and bearing its name to be free from defects in material and workmanship on the date of sale to the original purchaser for use. With the exception of any special, extended, or limited warranty published by Graco, Graco will, for a period of twelve months from the date of sale, repair or replace any part of the equipment determined by Graco to be defective. This warranty applies only when the equipment is installed, operated and maintained in accordance with Graco's written recommendations.

This warranty does not cover, and Graco shall not be liable for general wear and tear, or any malfunction, damage or wear caused by faulty installation, misapplication, abrasion, corrosion, inadequate or improper maintenance, negligence, accident, tampering, or substitution of non-Graco component parts. Nor shall Graco be liable for malfunction, damage or wear caused by the incompatibility of Graco equipment with structures, accessories, equipment or materials not supplied by Graco, or the improper design, manufacture, installation, operation or maintenance of structures, accessories, equipment or materials not supplied by Graco.

This warranty is conditioned upon the prepaid return of the equipment claimed to be defective to an authorized Graco distributor for verification of the claimed defect. If the claimed defect is verified, Graco will repair or replace free of charge any defective parts. The equipment will be returned to the original purchaser transportation prepaid. If inspection of the equipment does not disclose any defect in material or workmanship, repairs will be made at a reasonable charge, which charges may include the costs of parts, labor, and transportation.

**THIS WARRANTY IS EXCLUSIVE, AND IS IN LIEU OF ANY OTHER WARRANTIES, EXPRESS OR IMPLIED, INCLUDING BUT NOT LIMITED TO WARRANTY OF MERCHANTABILITY OR WARRANTY OF FITNESS FOR A PARTICULAR PURPOSE.**

Graco's sole obligation and buyer's sole remedy for any breach of warranty shall be as set forth above. The buyer agrees that no other remedy (including, but not limited to, incidental or consequential damages for lost profits, lost sales, injury to person or property, or any other incidental or consequential loss) shall be available. Any action for breach of warranty must be brought within two (2) years of the date of sale.

**GRACO MAKES NO WARRANTY, AND DISCLAIMS ALL IMPLIED WARRANTIES OF MERCHANTABILITY AND FITNESS FOR A PARTICULAR PURPOSE, IN CONNECTION WITH ACCESSORIES, EQUIPMENT, MATERIALS OR COMPONENTS SOLD BUT NOT MANUFACTURED BY GRACO.** These items sold, but not manufactured by Graco (such as electric motors, switches, hose, etc.), are subject to the warranty, if any, of their manufacturer. Graco will provide purchaser with reasonable assistance in making any claim for breach of these warranties.

In no event will Graco be liable for indirect, incidental, special or consequential damages resulting from Graco supplying equipment hereunder, or the furnishing, performance, or use of any products or other goods sold hereto, whether due to a breach of contract, breach of warranty, the negligence of Graco, or otherwise.

## FOR GRACO CANADA CUSTOMERS

The Parties acknowledge that they have required that the present document, as well as all documents, notices and legal proceedings entered into, given or instituted pursuant hereto or relating directly or indirectly hereto, be drawn up in English. Les parties reconnaissent avoir convenu que la rédaction du présente document sera en Anglais, ainsi que tous documents, avis et procédures judiciaires exécutés, donnés ou intentés, à la suite de ou en rapport, directement ou indirectement, avec les procédures concernées.

## Graco Information

For the latest information about Graco products, visit [www.graco.com](http://www.graco.com).

For patent information, see [www.graco.com/patents](http://www.graco.com/patents).

**To place an order**, contact your Graco Distributor or call to identify the nearest distributor.

**Phone:** 612-623-6921 **or Toll Free:** 1-800-328-0211 **Fax:** 612-378-3505

All written and visual data contained in this document reflects the latest product information available at the time of publication.

Graco reserves the right to make changes at any time without notice.

Original Instructions. This manual contains English. MM **3A3437**

**Graco Headquarters:** Minneapolis

**International Offices:** Belgium, China, Japan, Korea

**GRACO INC. AND SUBSIDIARIES • P.O. BOX 1441 • MINNEAPOLIS MN 55440-1441 • USA**

**Copyright 2016, Graco Inc. All Graco manufacturing locations are registered to ISO 9001.**

[www.graco.com](http://www.graco.com)

Revision F – October 2018