



# 248187 Rupture Disk Assembly Kit

309969C

**Install in Electric Reactor™ heater inlet manifold or in Hydraulic Reactor pump to prevent overpressurization.**



### Important Safety Instructions

Read all warnings and instructions in your Reactor manual. Save those instructions.

## Contents



Electric Reactor Kit Installation ..... 1  
 Hydraulic Reactor Kit Installation ..... 4  
 Graco Standard Warranty ..... 6  
 Graco Information ..... 6

## Electric Reactor Kit Installation

**NOTE:** To convert earlier style electric Reactor heaters that do not have rupture disk assemblies, order two kits.

### Disassembly

1. Turn main power OFF  . Disconnect power supply.
2. Relieve pressure, see Reactor operation manual.

						
Read warnings in Reactor repair manual. To avoid severe burns, wait for heaters and fluid to cool before installing kit.						

3. Wait for heaters and fluid to cool.
4. Remove back heater cover (C). See FIG. 1.

**NOTE: Use dropcloth or rags to protect Reactor and surrounding area from spills.**

5. Remove old parts.
  - a. *If replacing an existing rupture disk assembly (D), remove old assembly from heater inlet manifold (M). See FIG. 2.*
  - b. *If converting heaters that do not have an existing rupture disk assembly (D), remove plugs from locations A and B shown in FIG. 2, using a 3/8 allen wrench.*

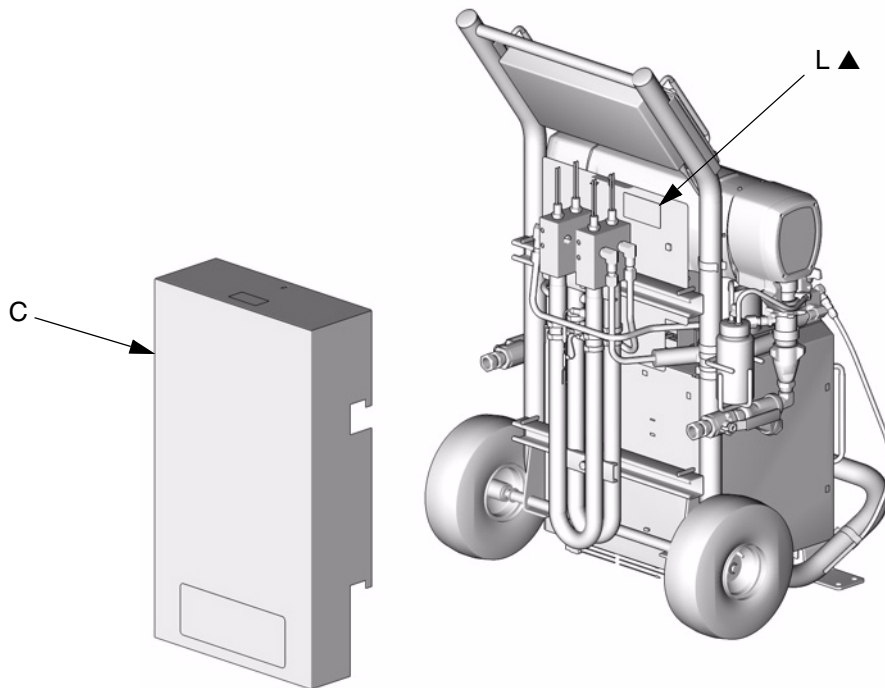

T13764a

**FIG. 1. Rear Heater Cover and 171001 Warning Label**

## Assembly

<p>Using a wrench on the rupture disk red housing can cause damage, resulting in a lower rupture pressure. To tighten the rupture disk assembly (D), use a wrench on the hex. Do not use a wrench on the red housing.</p>						

1. Apply pipe sealant and PTFE tape to rupture disk assembly (D) threads. See FIG. 2. Install as shown for applicable heater. Exhaust hole must be at bottom, angled slightly toward outside of heater compartment.

<p>To avoid severe burns, do not operate Reactor with heater cover (C) removed.</p>						

2. Apply 171001 Warning Label (L) to front heater cover, facing rear of Reactor. See FIG. 1.
- ▲ *Replacement Warning labels are available at no cost.*
3. Reinstall back heater cover (C). Return Reactor to service.

⚠ Apply PTFE tape and thread sealant to threads.

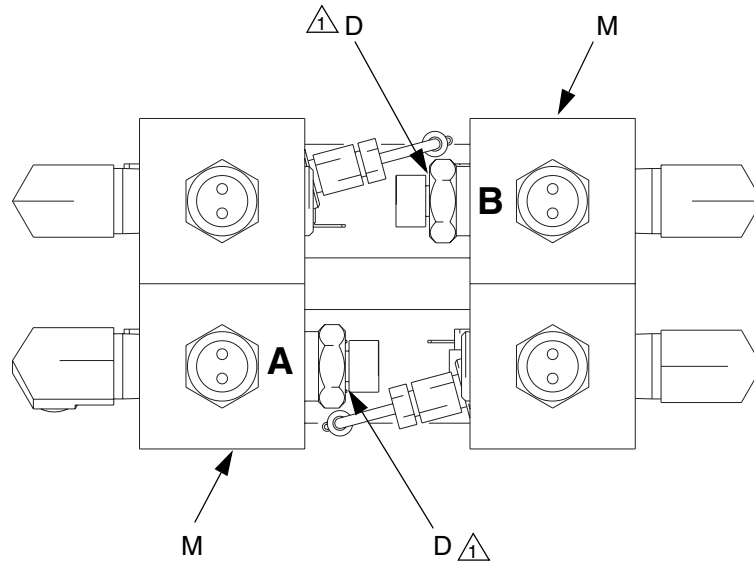

245962 and 245975 Heaters

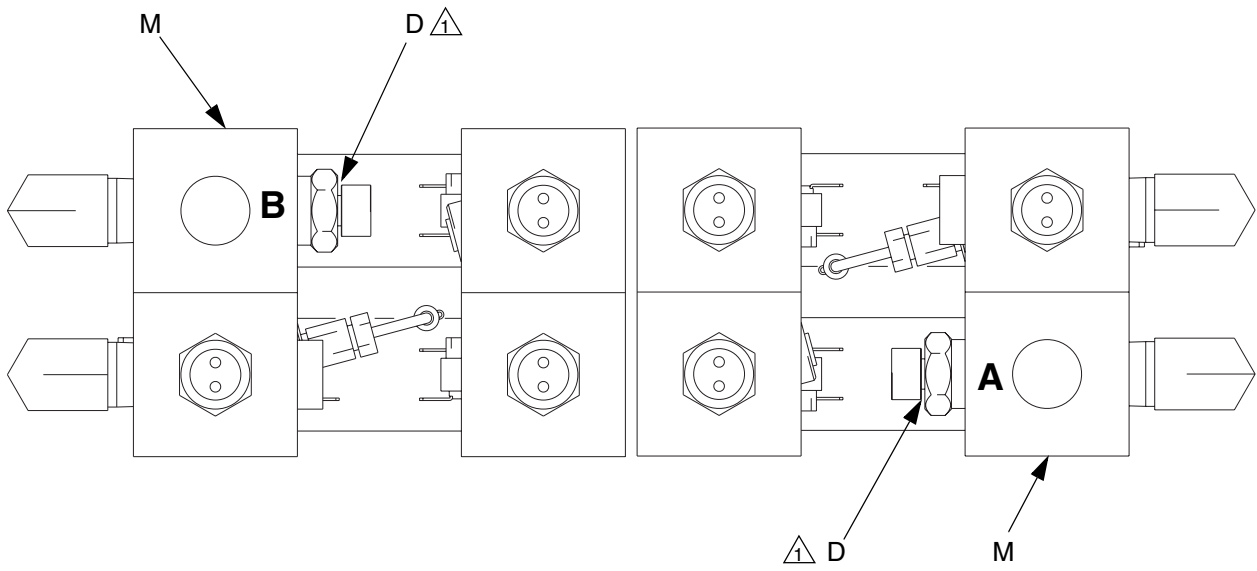



245963 Heaters

**FIG. 2. Install Rupture Disk Assemblies**

# Hydraulic Reactor Kit Installation

## Disassembly

1. Turn main power OFF . Disconnect power supply.
2. Relieve pressure, see Reactor operation manual.

						
Read warnings in Reactor repair manual. To avoid severe burns, wait for heaters and fluid to cool before installing kit.						

3. Wait for pump and fluid to cool.

**NOTE: Use dropcloth or rags to protect Reactor and surrounding area from spills.**

4. Remove old rupture disk assembly (D) from pump fitting (N). See FIG. 3.

## Assembly

					
Using a wrench on the rupture disk red housing can cause damage, resulting in a lower rupture pressure. To tighten the rupture disk assembly (D), use a wrench on the hex. Do not use a wrench on the red housing.					

Apply pipe sealant and PTFE tape to rupture disk assembly (D) threads. See FIG. 3. Install as shown for applicable pump. Exhaust hole must be at bottom.

### Hydraulic Reactors Pumpline

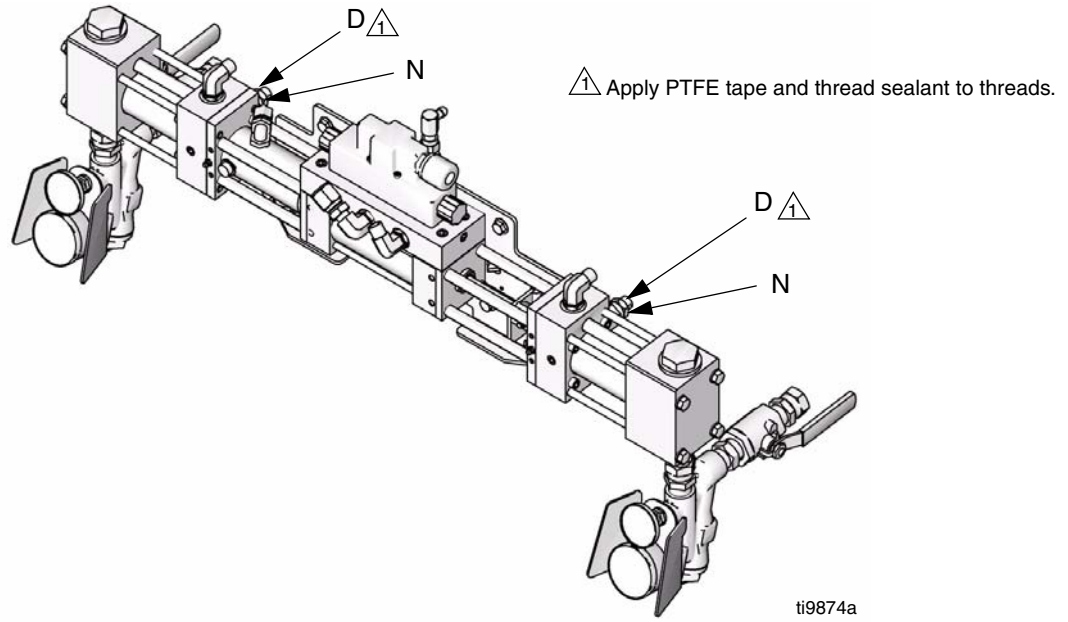

### Reactor H-VR Pumpline

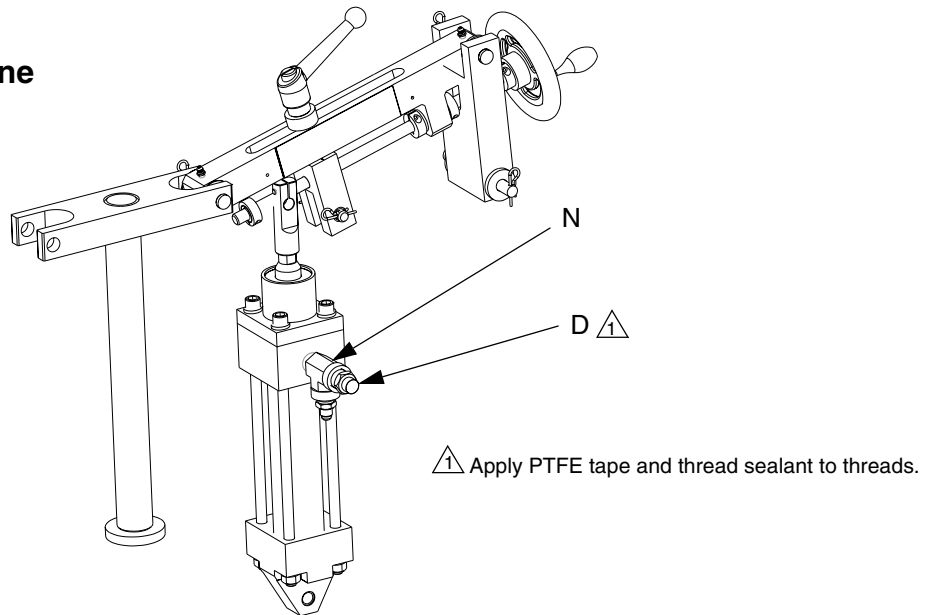

r\_256886\_313539\_3

FIG. 3. Hydraulic Systems

# Graco Standard Warranty

Graco warrants all equipment referenced in this document which is manufactured by Graco and bearing its name to be free from defects in material and workmanship on the date of sale to the original purchaser for use. With the exception of any special, extended, or limited warranty published by Graco, Graco will, for a period of twelve months from the date of sale, repair or replace any part of the equipment determined by Graco to be defective. This warranty applies only when the equipment is installed, operated and maintained in accordance with Graco's written recommendations.

This warranty does not cover, and Graco shall not be liable for general wear and tear, or any malfunction, damage or wear caused by faulty installation, misapplication, abrasion, corrosion, inadequate or improper maintenance, negligence, accident, tampering, or substitution of non-Graco component parts. Nor shall Graco be liable for malfunction, damage or wear caused by the incompatibility of Graco equipment with structures, accessories, equipment or materials not supplied by Graco, or the improper design, manufacture, installation, operation or maintenance of structures, accessories, equipment or materials not supplied by Graco.

This warranty is conditioned upon the prepaid return of the equipment claimed to be defective to an authorized Graco distributor for verification of the claimed defect. If the claimed defect is verified, Graco will repair or replace free of charge any defective parts. The equipment will be returned to the original purchaser transportation prepaid. If inspection of the equipment does not disclose any defect in material or workmanship, repairs will be made at a reasonable charge, which charges may include the costs of parts, labor, and transportation.

**THIS WARRANTY IS EXCLUSIVE, AND IS IN LIEU OF ANY OTHER WARRANTIES, EXPRESS OR IMPLIED, INCLUDING BUT NOT LIMITED TO WARRANTY OF MERCHANTABILITY OR WARRANTY OF FITNESS FOR A PARTICULAR PURPOSE.**

Graco's sole obligation and buyer's sole remedy for any breach of warranty shall be as set forth above. The buyer agrees that no other remedy (including, but not limited to, incidental or consequential damages for lost profits, lost sales, injury to person or property, or any other incidental or consequential loss) shall be available. Any action for breach of warranty must be brought within two (2) years of the date of sale.

**GRACO MAKES NO WARRANTY, AND DISCLAIMS ALL IMPLIED WARRANTIES OF MERCHANTABILITY AND FITNESS FOR A PARTICULAR PURPOSE, IN CONNECTION WITH ACCESSORIES, EQUIPMENT, MATERIALS OR COMPONENTS SOLD BUT NOT MANUFACTURED BY GRACO.** These items sold, but not manufactured by Graco (such as electric motors, switches, hose, etc.), are subject to the warranty, if any, of their manufacturer. Graco will provide purchaser with reasonable assistance in making any claim for breach of these warranties.

In no event will Graco be liable for indirect, incidental, special or consequential damages resulting from Graco supplying equipment hereunder, or the furnishing, performance, or use of any products or other goods sold hereto, whether due to a breach of contract, breach of warranty, the negligence of Graco, or otherwise.

## **FOR GRACO CANADA CUSTOMERS**

The Parties acknowledge that they have required that the present document, as well as all documents, notices and legal proceedings entered into, given or instituted pursuant hereto or relating directly or indirectly hereto, be drawn up in English. Les parties reconnaissent avoir convenu que la rédaction du présente document sera en Anglais, ainsi que tous documents, avis et procédures judiciaires exécutés, donnés ou intentés, à la suite de ou en rapport, directement ou indirectement, avec les procédures concernées.

# Graco Information

For the latest information about Graco products, visit [www.graco.com](http://www.graco.com).

**TO PLACE AN ORDER**, contact your Graco distributor, or call this number to identify the distributor closest to you:

**1-800-328-0211 Toll Free**

**612-623-6921**

**612-378-3505 Fax**

*All written and visual data contained in this document reflects the latest product information available at the time of publication.  
Graco reserves the right to make changes at any time without notice.*

*This manual contains English. MM 309969*

**Graco Headquarters:** Minneapolis

**International Offices:** Belgium, China, Japan, Korea

**GRACO INC. P.O. BOX 1441 MINNEAPOLIS, MN 55440-1441**

Copyright 2003, Graco Inc. is registered to ISO 9001

[www.graco.com](http://www.graco.com)

Revised 03/2009